

ANSI/APA PRG 320-2019

AMERICAN NATIONAL STANDARD

# Standard for Performance-Rated Cross-Laminated Timber



# AMERICAN NATIONAL STANDARD

Approval of an American National Standard requires review by ANSI that the requirements for due process, consensus, and other criteria for approval have been met by the standards developer. Consensus is established when, in the judgment of the ANSI Board of Standards Review, substantial agreement has been reached by directly and materially affected interests. Substantial agreement means more than a simple majority, but not necessarily unanimity. Consensus requires that all views and objections be considered, and that a concerted effort be made towards their resolution. The use of American National Standards is completely voluntary; their existence does not in any respect preclude anyone from manufacturing, marketing, purchasing, or using products, processes, or procedures not conforming to the standards.

The American National Standards Institute does not develop standards and will in no circumstances give an interpretation of any American National Standard. Moreover, no person shall have the right or authority to issue an interpretation of an American National Standard in the name of the American National Standards Institute. Requests for interpretations should be addressed to the secretariat or sponsor whose name appears on the title page of this standard.

**Caution Notice:** This American National Standard may be revised or withdrawn at any time. The procedures of the American National Standards Institute require that action be taken periodically to reaffirm, revise, or withdraw this standard. Purchasers of American National Standards may receive current information on all standards by calling or writing the American National Standards Institute.

American National Standards Institute  
25 West 43rd Street, 4th Floor  
New York, NY 10036  
[www.ansi.org](http://www.ansi.org)

Published by  
*APA – The Engineered Wood Association*  
7011 South 19th Street  
Tacoma, WA 98466

Copyright © 2020 by *APA – The Engineered Wood Association*  
All rights reserved.

Cover photo courtesy of Nordic Structures.

No part of this publication may be reproduced in any form, in an electronic retrieval system or otherwise, without the prior written permission of the publisher.

ANSI/APA PRG 320-2019

AMERICAN NATIONAL STANDARD

# Standard for Performance-Rated Cross-Laminated Timber

*APA – The Engineered Wood Association*

Approved January 6, 2020  
American National Standards Institute

## FOREWORD (This Foreword is not a part of American National Standard ANSI/APA PRG 320-2019)

This standard provides requirements and test methods for qualification and quality assurance for performance-rated cross-laminated timber (CLT), which is manufactured from solid-sawn lumber or structural composite lumber (SCL) intended for use in construction applications. Product performance classes are also specified.

The development of this consensus American National Standard was achieved by following the *Operating Procedures for Development of Consensus Standards* of APA – The Engineered Wood Association, approved by the American National Standards Institute (ANSI).

Inquiries or suggestions for improvement of this Standard should be directed to APA – The Engineered Wood Association at 7011 South 19th Street, Tacoma, WA 98466, [www.apawood.org](http://www.apawood.org).

# CONTENTS

<b>AMERICAN NATIONAL STANDARD</b> . . . . .	<b>ii</b>
<b>1 SCOPE</b> . . . . .	<b>1</b>
<b>2 REFERENCED DOCUMENTS</b> . . . . .	<b>1</b>
2.1 ASTM Standards . . . . .	1
2.2 Canadian Standards . . . . .	2
2.3 Other Standards . . . . .	3
<b>3 TERMINOLOGY</b> . . . . .	<b>3</b>
3.1 Definitions . . . . .	3
3.2 Terms Specific to This Standard . . . . .	3
<b>4 SYMBOLS</b> . . . . .	<b>9</b>
4.1 CLT Section and Mechanical Properties . . . . .	9
4.2 Lamination Mechanical Properties . . . . .	10
<b>5 PANEL DIMENSIONS AND DIMENSIONAL TOLERANCES</b> . . . . .	<b>11</b>
5.1 Thickness . . . . .	11
5.2 CLT Dimensional Tolerances . . . . .	11
5.3 Squareness . . . . .	11
5.4 Straightness . . . . .	11
<b>6 COMPONENT REQUIREMENTS</b> . . . . .	<b>11</b>
6.1 Laminations . . . . .	11
6.1.1 General . . . . .	11
6.1.2 Sawn lumber laminations . . . . .	12
6.1.3 Structural composite lumber (SCL) laminations . . . . .	12
6.1.4 Lamination sizes . . . . .	12
6.1.5 Moisture content . . . . .	13
6.1.6 Face-bonding surface . . . . .	13
6.1.7 Face-bonding dimensional tolerances . . . . .	13
6.1.8 Gaps between adjacent lamination edges . . . . .	13
6.2 Adhesives . . . . .	14
6.2.1 Requirements in the U.S. . . . .	14
6.2.2 Requirements in Canada . . . . .	14
6.2.3 Elevated temperature performance requirements in the U.S. and Canada . . . . .	15
6.3 Lamination Joints . . . . .	15
6.3.1 General . . . . .	15
6.3.2 End joints in laminations . . . . .	15
6.3.3 Edge and face joints between laminations . . . . .	16
<b>7 CLT PERFORMANCE CRITERIA</b> . . . . .	<b>17</b>
7.1 CLT Grade and Layup Requirements . . . . .	17
7.1.1 Basic CLT Grades and Layups . . . . .	17
7.1.2 Custom CLT Grades and Layups . . . . .	17
7.2 Structural Performance Requirements . . . . .	17
7.3 Appearance Classifications . . . . .	17

<b>8 QUALIFICATION AND PRODUCT MARKING</b> . . . . .	<b>18</b>
8.1 Qualification Requirements . . . . .	18
8.2 Plant Pre-Qualification . . . . .	18
8.2.1 General . . . . .	18
8.2.2 Fabrication of pre-qualification panels . . . . .	19
8.2.3 Conditioning of pre-qualification panels . . . . .	19
8.2.4 Specimens . . . . .	19
8.2.5 Shear tests . . . . .	21
8.2.6 Cyclic Delamination Test . . . . .	22
8.3 Qualification of Effective Bond Area . . . . .	22
8.3.1 General . . . . .	22
8.3.2 Sample selection and inspection . . . . .	22
8.4 Qualification for Structural Performance . . . . .	23
8.4.1 Required mechanical property qualification . . . . .	23
8.4.2 Optional mechanical property qualification . . . . .	23
8.5 Mechanical Property Qualification . . . . .	23
8.5.1 Sampling . . . . .	23
8.5.2 Moisture conditioning . . . . .	23
8.5.3 Flatwise bending properties . . . . .	24
8.5.4 Flatwise shear properties . . . . .	24
8.5.5 Edgewise bending properties . . . . .	25
8.5.6 Edgewise shear properties . . . . .	25
8.6 Process Changes Qualification . . . . .	26
8.7 Mill Specification . . . . .	27
8.8 Certification and Marking . . . . .	27
8.8.1 Certification . . . . .	27
8.8.2 Product marking . . . . .	27
8.8.3 Frequency of marking . . . . .	27
8.8.4 Custom products . . . . .	28
8.8.5 Voiding marks . . . . .	28
<b>9 QUALITY ASSURANCE</b> . . . . .	<b>28</b>
9.1 Objectives . . . . .	28
9.2 Process Control . . . . .	28
9.3 End, Face, and Edge Joints in Laminations . . . . .	28
9.3.1 Effective bonding area . . . . .	29
9.3.2 Lumber lamination grade limits . . . . .	29
9.3.3 Glue skip in the face bondline . . . . .	29
9.3.4 Additional consideration for face joints . . . . .	29
9.3.5 Additional consideration for end joints . . . . .	30
9.4 Finished Production Inspection . . . . .	30
9.5 Minor Variations . . . . .	30

Continued next page

# CONTENTS (continued)

## ANNEX A

Design Properties for PRG-320 CLT (Mandatory) . . . . .	31
---------------------------------------------------------	----

## ANNEX B.

### Practice for Evaluating Elevated Temperature Performance of Adhesives Used in Cross-Laminated Timber Using the

### Compartment Fire Test (CFT) Method (Mandatory). . . . . 38

B1	Scope . . . . .	38
B2	Referenced Documents . . . . .	38
B3	Terminology . . . . .	38
B3.1	Definition . . . . .	38
B3.2	Superimposed Load . . . . .	38
B4	Summary of Practice . . . . .	39
B5	Significance and Use . . . . .	39
B6	Sample Description . . . . .	39
B6.1	Dimensions . . . . .	39
B6.2	Fabrication . . . . .	39
B6.3	Adhesive . . . . .	39
B6.4	Moisture Content . . . . .	39
B7	Test Room Description . . . . .	39
B7.1	Test Room Dimensions . . . . .	39
B7.2	Floor-Ceiling Support . . . . .	40
B7.3	Front Wall . . . . .	40
B7.4	Back Wall . . . . .	40
B7.5	Non-Loadbearing Side Walls . . . . .	40
B7.6	Wall Opening Dimensions . . . . .	40
B7.7	Protected Beam . . . . .	40
B7.8	Burner Compartment . . . . .	40
B8	Instrumentation . . . . .	41
B8.1	Hot Gas Layer (Ceiling) Thermocouples . . . . .	41
B9	Loading . . . . .	41
B10	Calibration Test Method . . . . .	41
B11	Qualification Test Method . . . . .	42
B12	Acceptance Criteria . . . . .	42
B13	Report . . . . .	42

## APPENDIX X1

### Examples of CLT Appearance Classifications

(Non-Mandatory) . . . . .	44
X1-1 Architectural Appearance Classification . . . . .	44
X1-2 Industrial Appearance Classification . . . . .	44

## APPENDIX X2

### Test Setup Used in the Development of Annex B

### (Non-Mandatory) . . . . . 45

X2-1	Introduction . . . . .	45
X2-2	Test Room . . . . .	45
X2-2.1	Front Wall . . . . .	45
X2-2.2	Side Walls . . . . .	46
X2-2.3	Back Wall . . . . .	46
X2-2.4	I-beams . . . . .	46
X2-2.5	Back Section Ceiling . . . . .	46
X2-3	Gas Burner . . . . .	47
X2-3.1	Burner Construction . . . . .	47
X2-3.2	Burner Heat Release Rate Profile . . . . .	47

## APPENDIX X3

### Engineering Model Used in the Development of

### Design Values in Annex A (Non-Mandatory) . . . . . 53

X3.1	General . . . . .	53
X3.2	Flatwise Bending Moment . . . . .	53
X3.3	Flatwise Bending Stiffness . . . . .	54
X3.4	Flatwise Shear Rigidity . . . . .	55
X3.5	Flatwise (Rolling) Shear Capacity . . . . .	56

## APPENDIX X4

### History of Standard (Non-Mandatory) . . . . . 57

# 1 SCOPE

Cross-laminated timber (CLT) panels referenced in this standard are defined in 3.2 and shall be qualified and marked in accordance with this standard. This standard provides requirements for dimensions and tolerances, performance, test methods, quality assurance, and marking for CLT panels.

CLT panels shall be used in dry service conditions, such as in most covered structures, where the average equilibrium moisture content of solid wood is less than 16 percent in the U.S. and is 15 percent or less over a year without exceeding 19 percent in Canada. CLT panels qualified in accordance with the provisions of this standard are intended to resist the effects of moisture on structural performance as may occur due to construction delays or other conditions of similar severity. Products marked in accordance with this standard shall be used in accordance with the installation requirements prescribed in the recommendations provided by the CLT manufacturer, an *approved agency*, and/or its trade association. Finger joining, edge gluing, and face gluing between CLT panels, and camber of CLT panels are beyond the scope of this standard.

The annex contained in this standard is mandatory, while notes and appendices are non-mandatory. This standard incorporates the U.S. customary units as well as the International System of Units (SI). The values given in the U.S. customary units are the standard in the U.S. and the SI values given in parentheses are the standard in Canada.

# 2 REFERENCED DOCUMENTS

This standard incorporates dated references. Subsequent amendments or revisions to these references apply to this standard only when incorporated into this standard by amendments or revisions.

## 2.1 ASTM Standards

*ASTM D9-12* Standard Terminology Relating to Wood and Wood-Based Products

*ASTM D198-15* Standard Test Methods of Static Tests of Lumber in Structural Sizes

*ASTM D905-08 (2013)* Standard Test Method for Strength Properties of Adhesive Bonds in Shear by Compression Loading

*ASTM D907-15* Standard Terminology of Adhesives

*ASTM D1037-12* Standard Test Methods for Evaluating Properties of Wood-Base Fiber and Particle Panel Materials

*ASTM D2395-17* Standard Test Methods for Specific Gravity of Wood and Wood-Base Materials

*ASTM D2559-12a (2018)* Standard Specification for Adhesives for Bonded Structural Wood Products for Use Under Exterior Exposure Conditions

*ASTM D2915-17* Standard Practice for Sampling and Data-Analysis for Structural Wood and Wood-Based Products

*ASTM D3737-18e1* Standard Practice for Establishing Stresses for Structural Glued Laminated Timber (Glulam)

*ASTM D4761-19* Standard Test Methods for Mechanical Properties of Lumber and Wood-Based Structural Material

*ASTM D5055-19* Standard Specification for Establishing and Monitoring Structural Capacities of Prefabricated Wood I-Joists

*ASTM D5456-19* Standard Specification for Evaluation of Structural Composite Lumber Products

*ASTM D6815-09 (2015)* Standard Specification for Evaluation of Duration of Load and Creep Effects of Wood and Wood-Based Products

*ASTM D7247-17* Standard Test Method for Evaluating the Shear Strength of Adhesive Bonds in Laminated Wood Products at Elevated Temperatures

*ASTM D7374-08 (2015)* Standard Practice for Evaluating Elevated Temperature Performance of Adhesives Used in End-Jointed Lumber

## 2.2 **CSA Standards**

*CAN/CSA O86-14 (Reprint 2016)* Engineering Design in Wood

*CAN/ULC S101-14* Standard Methods of Fire Endurance Tests of Building Construction and Materials

*CSA O112.10-08 (R2013)* Evaluation of Adhesives for Structural Wood Products (Limited Moisture Exposure)

*CSA O122-16* Structural Glued-Laminated Timber

*CSA O141-05 (R2014)* Softwood Lumber

*CSA O177-06 (R2015)* Qualification Code for the Manufacturers of Structural Glued-Laminated Timber



## 2.3 Other Standards

*AITC Test T107-2007* Shear Test

*ANSI 405-2018* Standard for Adhesives for Use in Structural Glued Laminated Timber

*ANSI A190.1-2017* Structural Glued Laminated Timber

*ANSI/AWC NDS-2018* National Design Specification for Wood Construction

*ISO/IEC 17011-2017* Conformity Assessment—General Requirements for Accreditation Bodies Accrediting Conformity Assessment Bodies

*ISO/IEC 17020-2012* Conformity Assessment—Requirements for Operation of Various Types of Bodies Performing Inspection

*ISO/IEC 17025-2017* General Requirements for the Competence of Testing and Calibration Laboratories

*ISO/IEC 17065-2012* Conformity Assessment—Requirements for Bodies Certifying Products, Processes, and Services

*NLGA Standard Grading Rules for Canadian Lumber (2017)*

*NLGA SPS 1-2017* Special Products Standard for Fingerjoined Structural Lumber

*NLGA SPS 2-2019* Special Products Standard for Machine Graded Lumber

*NLGA SPS 4-2014* Special Products Standard for Fingerjoined Machine Graded Lumber

*NLGA SPS 6-2015* Special Products Standard for Structural Face-Glued Lumber

*U.S. Product Standard PS 1-09* Structural Plywood

*U.S. Product Standard PS 20-15* American Softwood Lumber Standard

## 3 TERMINOLOGY

### 3.1 Definitions

See the referenced documents for definitions of terms used in this standard.

### 3.2 Terms Specific to This Standard

**ASD Reference Design Value**—design value used in the U.S. based on normal duration of load, dry service conditions, and reference temperatures up to 100°F (38°C) for Allowable Stress Design (ASD)

**Adhesive**—a chemical substance capable of bonding materials together (aka Glue)

**Adherend**—a material held to another material by an adhesive

**Approved Agency (Canada)**—an established and recognized agency regularly engaged in conducting certification services, when such agency has been approved by regulatory bodies (see *Qualified Certification Agency*)

**Approved Agency (U.S.)**—an established and recognized agency regularly engaged in conducting tests or furnishing inspection services, when such agency has been approved by regulatory bodies (see *Qualified Inspection Agency* and *Qualified Testing Agency*)

**Billet**— an unfinished CLT panel formed by a single pressing operation

*Note 1: One or several finished CLT panels may be produced from a billet*

**Bond**—the attachment at an interface between adhesive and adherends or the act of attaching adherends together by adhesive

**Bondline**—the layer of adhesive that attaches two adherends

- **Face bondline**—the bondline joining the wide faces of laminations in adjacent layers
- **Bondline**—the optional bondline joining the narrow faces of adjacent laminations within one layer

**Characteristic Values**—the structural property estimate, typically a population mean for stiffness properties or a tolerance limit (5th percentile with 75% confidence) for strength properties, as estimated from the test data that is representative of the population being sampled

**Certificate of Conformance**—a certificate issued by an approved agency certifying the product as in conformance to a standard or standards

**Cross-Laminated Timber (CLT)**—a prefabricated engineered wood product made of at least three orthogonal layers of graded sawn lumber or structural composite lumber (SCL) that are laminated by gluing with structural adhesives

**CLT Grade**—a class of CLT determined by the combination of grades of laminations in the longitudinal and transverse layers

*Note 2: Basic CLT grades and layups in this standard are listed in Annex A. Custom CLT grades and layups may be established in accordance with 7.1.2 (see Layup).*

**CLT Length**—dimension of the CLT panel measured parallel to the major strength direction

*Note 3: The length and width of CLT defined in this standard are based on the CLT panel face layer orientation and may not be related to the end-use applications, such as wall, roof, and floor.*

**CLT Panel**—a single piece of CLT

**CLT Thickness**—dimension of the CLT panel measured perpendicular to the plane of the panel

**CLT Width**—dimension of the CLT panel measured perpendicular to the major strength direction

**Cure**—the process of converting an adhesive into a fixed or hardened state by chemical and/or physical action

**Delamination**—the separation of layers in a laminate due to failure of the adhesive either in the adhesive itself or at the interface between the adhesive and the adherend

**Note 4:** For a specimen, the average delamination is calculated as the ratio of the total length of delamination on all exposed bond lines divided by the total length of all exposed bond lines, in percentage.

**Edge (Panel Edge)**—the narrow face of a panel that exposes the ends or narrow faces of the laminations

**Edgewise Bending**—bending of CLT under loads applied to the panel edge (see Figure 1) creating in-plane bending and edgewise shear, also known as in-plane shear or shear through-the-thickness

FIGURE 1

**EDGEWISE BENDING IN THE MAJOR (LEFT) AND MINOR (RIGHT) CLT STRENGTH DIRECTIONS**

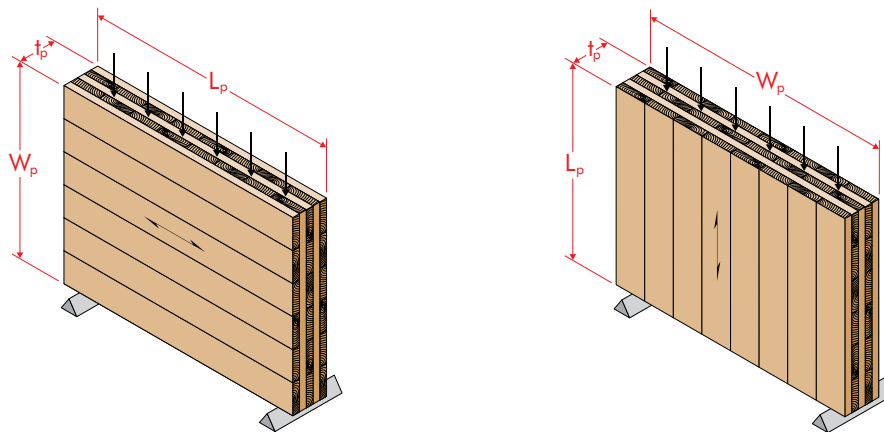

**Edge Joint**—a joint of the narrow faces of adjacent laminations within a CLT layer with or without gluing

**Effective Bonding Area**—proportion of the lamination wide face averaged over its length that is able to form a close contact bond upon application of pressure

**End Joint**—a joint made by gluing the ends of two pieces of laminations within a CLT layer

**Face**—one of the four longitudinal surfaces of a piece or panel

- **Lamination narrow face**—the face with the least dimension perpendicular to the lamination length
- **Lamination wide face**—the face with the largest dimension perpendicular to the lamination length
- **Panel face**—the face of the CLT length-width plane

**Flatwise Bending**—bending of CLT under transverse loads applied to the panel face (see Figure 2) creating out-of-plane bending and flatwise shear, also known as planar or rolling shear

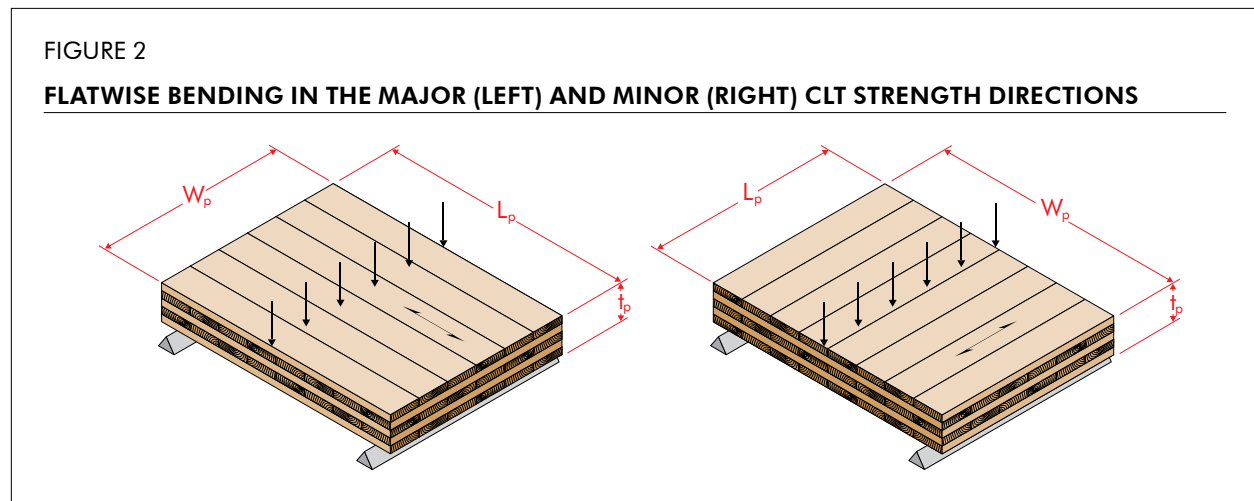

**Lamination**—a piece of sawn lumber or structural composite lumber, including stress rated boards, remanufactured lumber, or end-joined lumber, which has been prepared and qualified for laminating

**Layer**—an arrangement of laminations laid out parallel to each other in one plane

- **Longitudinal layer**—a layer with the laminations oriented parallel to the major strength direction
- **Transverse layer**—a layer with the laminations oriented perpendicular to the major strength direction, also referred to as cross layer

**Layup**—an arrangement of layers in a CLT panel determined by the grade(s), number, orientations, and thickness(es) of layers

**LSD Design Value**—design value used in Canada based on standard-term duration of load, dry service conditions, and temperatures up to 122°F (50°C) except for occasional exposures to 150°F (65°C) for Limit States Design (LSD)

**Major Strength Direction**—direction parallel to strength direction of the laminations in the outer layers of the CLT panel

**Manufacturing Standard**—a document that establishes the minimum requirements for manufacturing practices, staff, facilities, equipment, and specific quality assurance processes, including inspection (in the U.S.) and/or certification (in Canada), by which the product is manufactured

**Mill Specification**—a manufacturing specification based on product evaluation to be used for quality assurance purposes by the manufacturer and the *approved agency*

**Minor Strength Direction**—direction of the grain of the inner layers perpendicular to the major strength direction of the CLT panel

**Qualified Certification Agency (Canada)**—an agency meeting the following requirements:

- a. has trained personnel to perform product certification in compliance with all applicable requirements specified in this standard,
- b. has procedures to be followed by its personnel in performance of the certification,
- c. has no financial interest in, or is not financially dependent upon, any single company manufacturing the product being certified,
- d. is not owned, operated, or controlled by any such company, and
- e. is accredited by a recognized accreditation body under ISO/IEC 17065

**Qualified Inspection Agency (U.S.)**—an agency meeting the following requirements:

- a. has trained personnel to verify that the grading, measuring, species, construction, bonding, workmanship, and other characteristics of the products as determined by inspection in compliance with all applicable requirements specified in this standard,
- b. has procedures to be followed by its personnel in performance of the inspection,
- c. has no financial interest in, or is not financially dependent upon, any single company manufacturing the product being inspected,
- d. is not owned, operated, or controlled by any such company, and
- e. is accredited by a recognized accreditation body under ISO/IEC 17020

**Qualified Testing Agency**—an agency meeting the following requirements:

- a. has access to the facilities and trained technical personnel to conduct testing on the characteristics of the products by sampling and testing in compliance with all applicable requirements specified in this standard,
- b. has procedures to be followed by its personnel in performance of the testing,
- c. has no financial interest in, or is not financially dependent upon, any single company manufacturing the product being tested,
- d. is not owned, operated, or controlled by any such company, and
- e. is accredited by a recognized accreditation body under ISO/IEC 17025

**Recognized Accreditation Body**—an organization complying with ISO/IEC 17011 and recognized by the regulatory body having jurisdiction as qualified to evaluate and accredit certification agencies, inspection agencies and/or testing agencies

**Remanufactured Lumber**—lumber that meets the requirements of Section 5.4 of ANSI A190.1 in the U.S., or NLGA SPS 1, 2, 4, or 6 in Canada

**Sample**—one or more items taken as representative of a population or portion of material taken without bias from a bulk of material for assessment

**Specimen**—an individual piece of material or product selected for testing

**Structural Composite Lumber (SCL)**—an engineered wood product that is intended for structural use and bonded with adhesives, and meeting the definition and requirements of ASTM D5456

**Wood Failure**—the rupturing of wood fibers from the specified block shear test on bonded specimens, measured as the area of wood fiber remaining at the bondline and expressed as a percentage of total area involved in such failure

## 4 SYMBOLS

### 4.1 CLT Section and Mechanical Properties

Symbol	Definition	Reference(s)
$E_{e,0}$	Effective edgewise bending modulus of elasticity of CLT, in psi (MPa), in the major strength direction, used with $I_{e,0}$ when calculating edgewise bending stiffness	8.5.5.2
$E_{e,90}$	Effective edgewise bending modulus of elasticity of CLT, in psi (MPa), in the minor strength direction, used with $I_{e,90}$ when calculating edgewise bending stiffness	8.5.5.2
$(EI)_{eff,f,0}$	Effective flatwise bending stiffness of CLT, in lbf-in <sup>2</sup> /ft (N-mm <sup>2</sup> /m) of width, in the major strength direction	8.5.3.2 and Tables A2 and A4
$(EI)_{eff,f,90}$	Effective flatwise bending stiffness of CLT, in lbf-in <sup>2</sup> /ft (N-mm <sup>2</sup> /m) of width, in the minor strength direction	8.5.3.2 and Tables A2 and A4
$f_{b,e,0}$	Effective LSD specified edgewise bending strength of CLT, in MPa, in the major strength direction, used with $S_{e,0}$ when calculating LSD edgewise bending moment resistance.	8.5.5.2
$F_{b,e,0}$	Effective ASD reference edgewise bending stress of CLT, in psi, in the major strength direction, used with $S_{e,0}$ when calculating ASD reference edgewise bending moment.	8.5.5.2
$f_{b,e,90}$	Effective LSD specified edgewise bending strength of CLT, in MPa, in the minor strength direction, used with $S_{e,90}$ when calculating LSD edgewise bending moment resistance.	8.5.5.2
$F_{b,e,90}$	Effective ASD reference edgewise bending stress of CLT, in psi, in the minor strength direction, used with $S_{e,90}$ when calculating ASD reference edgewise bending moment.	8.5.5.2
$(f_b S)_{eff,f,0}$	Effective LSD flatwise bending moment resistance of CLT, in N-mm/m of width, in the major strength direction	8.5.3.2 and Table A4
$(F_b S)_{eff,f,0}$	Effective ASD reference flatwise bending moment of CLT, in lbf-ft/ft of width, in the major strength direction	8.5.3.2 and Table A2
$(f_b S)_{eff,f,90}$	Effective LSD flatwise bending moment resistance of CLT, in N-mm/m of width, in the minor strength direction	8.5.3.2 and Table A4
$(F_b S)_{eff,f,90}$	Effective ASD reference flatwise bending moment of CLT, in lbf-ft/ft of width, in the minor strength direction	8.5.3.2 and Table A2
$f_{v,e,0}$	LSD specified edgewise shear strength of CLT, in MPa, in the major strength direction, used with $t_p$ when calculating LSD edgewise shear resistance.	8.5.6.2
$F_{v,e,0}$	ASD reference edgewise shear stress of CLT, in psi, in the major strength direction, used with $t_p$ when calculating ASD reference edgewise shear capacity.	8.5.6.2
$f_{v,e,90}$	LSD specified edgewise shear strength of CLT, in MPa, in the minor strength direction, used with $t_p$ when calculating LSD edgewise shear resistance.	8.5.6.2
$F_{v,e,90}$	ASD reference edgewise shear stress of CLT, in psi, in the minor strength direction, used with $t_p$ when calculating ASD reference edgewise shear capacity	8.5.6.2
$G_{e,0}$	Effective modulus of rigidity (shear modulus) in edgewise bending of CLT, in psi (MPa), in the major strength direction, used with $t_p$ when calculating edgewise shear stiffness	8.5.6.2
$G_{e,90}$	Effective modulus of rigidity (shear modulus) in edgewise bending of CLT, in psi (MPa), in the minor strength direction, used with $t_p$ when calculating edgewise shear stiffness	8.5.6.2
$(GA)_{eff,f,0}$	Effective shear stiffness in flatwise bending of CLT in lbf/ft (N/m) of width in the major strength direction	8.5.4.2, and Tables A2 and A4
$(GA)_{eff,f,90}$	Effective shear stiffness in flatwise bending of CLT in lbf/ft (N/m) of width in the minor strength direction	8.5.4.2, and Tables A2 and A4
$I_{e,0}$	Gross moment of inertia of CLT in edgewise bending in the major strength direction, in in. <sup>4</sup> (mm <sup>4</sup> ), for a specific panel width (beam depth), calculated as $\frac{W_p^3 t_p}{12}$	8.5.5.2

Symbol	Definition	Reference(s)
$I_{e,90}$	Gross moment of inertia of CLT in edgewise bending in the minor strength direction, in in. <sup>4</sup> (mm <sup>4</sup> ), for a specific panel length (beam depth), calculated as $\frac{L_p^3 t_p}{12}$	8.5.5.2
$L_p$	Length of CLT panel in ft (m), measured in the major strength direction	Figures 1 and 2
$S_{e,0}$	Gross section modulus of CLT in edgewise bending in the major strength direction, in in. <sup>3</sup> (mm <sup>3</sup> ) for a specific CLT width (beam depth), calculated as $\frac{W_p^2 t_p}{6}$	8.5.5.2
$S_{e,90}$	Gross section modulus of CLT in edgewise bending in the minor strength direction, in in. <sup>3</sup> (mm <sup>3</sup> ) for a specific CLT length (beam depth), calculated as $\frac{L_p^2 t_p}{6}$	8.5.5.2
$t_p$	Gross thickness of CLT panel, in in. (mm)	Figures 1 and 2, Tables A2 and A4, and 8.5.6.2
$v_{s,0}$	LSD flatwise shear resistance, in N/m of width, in the major strength direction	8.5.4.2 and Table A4
$V_{s,0}$	ASD reference flatwise shear capacity, in lbf/ft of width, in the major strength direction	8.5.4.2 and Table A2
$v_{s,90}$	LSD flatwise shear strength, in N/m of width, in the minor strength direction	8.5.4.2 and Table A4
$V_{s,90}$	ASD reference flatwise shear capacity, in lbf/ft of width, in the minor strength direction	8.5.4.2 and Table A2
$W_p$	Width of CLT panel in ft (m), measured in the minor strength direction	Figures 1 and 2

## 4.2 Lamination Mechanical Properties

Symbol	Definition	Reference(s)
$E$	Modulus of elasticity of a lamination, in psi (MPa)	Tables A1 and A3
$f_b$	Characteristic bending strength or LSD specified bending strength of a lamination, in psi (MPa)	Table A3
$F_b$	ASD reference bending stress of a lamination, in psi	Table A1
$f_c$	Characteristic axial compressive strength or LSD specified axial compressive strength of a lamination, in psi (MPa)	Table A3
$F_c$	ASD reference axial compressive stress of a lamination, in psi	Table A1
$f_s$	Characteristic planar (rolling) shear strength or LSD specified planar (rolling) shear strength of a lamination, in psi (MPa)	Table A3
$F_s$	ASD reference planar (rolling) shear stress of a lamination, in psi	Table A1
$f_t$	Characteristic axial tensile strength or LSD specified axial tensile strength of a lamination, in psi (MPa)	Table A3
$F_t$	ASD reference axial tensile stress of a lamination, in psi	Table A1
$f_v$	Characteristic shear strength or LSD specified shear strength of a lamination, in psi (MPa)	Table A3
$F_v$	ASD reference shear stress of a lamination, in psi	Table A1
$G$	Modulus of rigidity (shear modulus) of a lamination, in psi (MPa)	Tables A1 and A3



## 5 PANEL DIMENSIONS AND DIMENSIONAL TOLERANCES

### 5.1 CLT Thickness

The CLT thickness shall not exceed 20 inches (508 mm).

### 5.2 CLT Dimensional Tolerances

Dimension tolerances permitted at the time of manufacturing shall be as follows:

- CLT Thickness:  $\pm 1/16$  inch (1.6 mm) or 2% of the CLT thickness, whichever is greater
- CLT Width:  $\pm 1/8$  inch (3.2 mm)
- CLT Length:  $\pm 1/4$  inch (6.4 mm)

Textured or other face or edge finishes are permitted to alter the tolerances specified in this section. The designer shall compensate for any loss in cross-section and/or specified strength of such alterations.

*Note 5: The manufacturer may be contacted for recommendations.*

### 5.3 Squareness

Unless specified otherwise, the length of the two panel face diagonals measured between panel corners shall not differ by more than 1/8 inch (3.2 mm).

### 5.4 Straightness

Unless specified otherwise, deviation of edges from a straight line between adjacent panel corners shall not exceed 1/16 inch (1.6 mm).

## 6 COMPONENT REQUIREMENTS

### 6.1 Laminations

#### 6.1.1 General

Lumber meeting the requirements of 6.1.2 and structural composite lumber meeting the requirements of 6.1.3 shall be permitted for use as laminations in CLT manufacturing and shall meet the requirements specified in 6.1.4 through 6.1.8. Laminations within the same layer shall be of the same thickness, type, grade, and species or species combination.

*Note 6: Laminations in different layers may be of different thicknesses, types, grades, and species or species combinations.*

### 6.1.2 Sawn lumber laminations

- a. Lumber species – Lumber of any softwood species or species combinations recognized by American Lumber Standards Committee (ALSC) under PS 20 or Canadian Lumber Standards Accreditation Board (CLSAB) under CSA O141 with a minimum published specific gravity of 0.35, as published in the National Design Specification for Wood Construction (NDS) in the U.S. and CSA O86 in Canada, shall be permitted.
- b. Lumber grades – The minimum grade of lumber in the longitudinal layers of CLT shall be 1200f-1.2E MSR or visual grade No. 2. The minimum grade of lumber in the transverse layers of CLT shall be visual grade No. 3. Remanufactured lumber shall be considered as equivalent to solid-sawn lumber when qualified in accordance with Section 5.4 of ANSI A190.1 in the U.S. or SPS 1, 2, 4, or 6 in Canada. Proprietary lumber grades meeting or exceeding the mechanical properties of the lumber grades specified above shall be permitted for use provided that they are qualified in accordance with the requirements of an *approved agency*.

**Note 7:** *ASTM D5055 provides guidance for proprietary lumber grades used specifically in I-joist applications.*

### 6.1.3 Structural composite lumber (SCL) laminations

Laminated Strand Lumber (LSL), Laminated Veneer Lumber (LVL), Oriented Strand Lumber (OSL), and Parallel Strand Lumber (PSL) meeting the requirements of ASTM D5456 and with a minimum published equivalent specific gravity of 0.35 shall be permitted.

### 6.1.4 Lamination sizes

- a. Width – For longitudinal layers (major strength direction), the net lamination width shall not be less than 1.75 times the net lamination thickness. For transverse layers (minor strength direction), the net width of a lamination, or the combined width of an edge-bonded lamination or remanufactured lumber shall not be less than 3.5 times the net lamination thickness unless the interlaminar shear strength and creep are evaluated by testing in accordance with Section 8.5.5 and the principles of ASTM D6815, respectively. Laminations made of SCL shall be permitted to be full CLT width.
- b. Thickness – The net lamination thickness in any layer at the time of gluing shall not be less than 5/8 inch (16 mm) or more than 2 inches (51 mm). The lamination thickness shall not vary within the same CLT layer subject to the tolerances specified in 6.1.7.

**Note 8:** *The CLT manufacturer should contact the SCL manufacturer to ensure that protective coatings have not been applied to the surface of the SCL that may hamper the face bonding of the SCL laminations.*

### 6.1.5 Moisture content

The moisture content of the laminations at the time of CLT manufacturing shall be typically  $12 \pm 3\%$  and  $8 \pm 3\%$ , for lumber and SCL laminations, respectively. Lower lamination moisture contents shall be permitted if the adhesive bond performance is qualified at the lower moisture content in accordance with 6.3.3, 8.2.5, and 8.2.6, and meets the recommendations provided by the adhesive manufacturer. When a lower moisture content is used, the as-manufactured moisture content of the laminations shall be within  $\pm 3\%$  of the average moisture content from the qualification.

### 6.1.6 Face–bonding surface

a. General – Laminations shall be prepared to provide bonding surfaces for adhesive bond performance required by this standard and to meet the recommendations provided by the adhesive manufacturer.

*Note 9: Satisfactory face-bonding surfaces are typically free from dust, foreign matter, and exudation that are detrimental to adhesive bond performance.*

b. Lumber – All face-bonding surfaces shall be planed or sanded prior to face bonding.

The process used to prepare bonding surfaces shall be approved by the *approved agency*.

*Note 10: Satisfactory face-bonding surfaces are typically free of raised grain, torn grain, skip, burns, glazing or other deviations from the plane of the surface that might interfere with the contact of sound wood fibers in the bonding surfaces, except for minor local variations. It may be necessary to plane or sand the lumber lamination surfaces within 48 hours of face bonding for some wood species.*

c. SCL – Planing or sanding of face-bonding surfaces prior to face bonding shall not be required unless indicated otherwise by the adhesive bond qualification or required to meet lamination thickness tolerances.

### 6.1.7 Face–bonding dimensional tolerances

At the time of face bonding, the thickness variation across the width of a lumber lamination shall not exceed  $\pm 0.008$  inch (0.20 mm) and the thickness variation across the width of a SCL lamination shall not exceed  $\pm 0.008$  inch (0.20 mm) in every 12-inch (30.5-mm) width. The thickness variation along the length of a lumber or SCL lamination shall not exceed  $\pm 0.012$  inch (0.30 mm).

*Note 11: Cup and twist, if present, should be small enough to be flattened out by pressure in bonding.*

### 6.1.8 Gaps between adjacent lamination edges

At the time of CLT manufacturing, laminations in the CLT layers shall be tightly fit.

Gaps between adjacent lamination edges (edge joint gaps) are permitted as follows: Edge joint gaps in face layers shall not exceed 1/4 inch (6.4 mm) and edge joint gaps between adjacent lamination edges in other layers shall not exceed 3/8 inch (9.5 mm).

**Note 12:** Edge joint gaps are typically caused by imperfections such as crook or twist in individual laminations, which prevent contact along the full length of edges. Consequently, small gaps may occur in a layer at the time of manufacturing. These gaps are not typically present between all laminations in the layer or along the full length of individual edges. Small natural growth characteristics of lumber, such as knots and wane, are not considered as part of an edge joint gap and should not be included in the measurements. The intent of this standard is for the laminations to be tightly fit with no individual gap exceeding the prescribed limits.

**Note 13:** This provision applies at the time when the CLT billet exits the press and the quality assurance measures are implemented at the plant. Gaps in face layers may increase slightly as CLT billets or panels season.

**Note 14:** When edge joints of laminations are not bonded with an adhesive or not filled with a filler, small air gaps are common for CLT (see Note 12). These gaps will affect the air tightness through the CLT thickness, and the effect will depend on the number of CLT layers and actual gap size as manufactured. If air tightness is an important requirement, such as in fire containment, thermal resistance, or sound attenuation, additional measures should be incorporated in the assembly design, such as the use of an air-tight membrane (e.g. concrete floor topping or finished gypsum wallboard ceiling for floor-ceiling assemblies or finished gypsum wallboard or plaster for wall assemblies).

## 6.2 Adhesives

Adhesives used for CLT manufacturing shall meet the requirements specified in this section.

### 6.2.1 Requirements in the U.S.

Adhesives used in CLT shall meet the requirements of ANSI 405 with the following exceptions:

- a. Section 2.1.6 of ANSI 405 is not required, and
- b. The CSA O177 small-scale flame test (Sections 2.1.7 and 3.7 of ANSI 405) shall be conducted using CLT specimens of the same size and geometry as the structural glued laminated timber specimens.

### 6.2.2 Requirements in Canada

Adhesives used in CLT shall meet the requirements of CSA O112.10, and Sections 2.1.3, 2.1.7, 3.3, and 3.7 of ANSI 405 with the following exception:

- a. The CSA O177 small-scale flame test (Sections 2.1.7 and 3.7 of ANSI 405) shall be conducted using CLT specimens of the same size and geometry as the structural glued laminated timber specimens.

**Note 15:** The CSA O177 small-scale flame test specimens should be made with orthogonal 0.78-inch (20-mm) laminations to replicate a CLT configuration, resulting in 8 laminations (6.3 inches or 160 mm) in height, and approximately 6 inches (150 mm) in width and 1.6 inches (40 mm) in thickness. There should be no edge joints within the inner 6 laminations. Whenever possible, the pith should be centered along the lamination.

### 6.2.3 Elevated temperature performance requirements in the U.S. and Canada

Adhesives shall be evaluated and comply with the requirements for elevated temperature performance in accordance with Annex B.

**Note 16:** The intent of the elevated temperature performance evaluation is to identify and exclude use of adhesives that permit CLT char layer fall-off resulting in fire regrowth during the cooling phase of a fully developed fire.

## 6.3 Lamination Joints

### 6.3.1 General

The lamination joints of CLT shall meet the requirements specified in this section.

### 6.3.2 End joints in laminations

End joints in each lamination shall be either finger-jointed or scarf-jointed. Butt joints shall not be permitted. The manufacturing of end joints shall follow ANSI A190.1 in the U.S. or CSA O122 in Canada. The strength, wood failure, and bond durability of lamination end joints shall be qualified in accordance with the requirements specified herein.

- a. Full-size end-joint specimens shall be prepared from lumber or SCL selected at random from stock meeting the requirements of 6.1.1 to 6.1.5. Additional requirements specified in the CLT plant manual procedures and quality manuals shall be followed.
- b. A minimum of 30 full-size end-joint specimens shall be tested in tension. The specimens shall be centered between the grips of the testing machine, which are spaced at minimum 24 inches (610 mm) apart and tested to failure in approximately 3 to 5 minutes at a constant rate of loading. The accuracy of the load measurements shall be within  $\pm 1\%$ . Average wood failure of all end-joint specimens tested shall be equal to or greater than 80%. The characteristic tensile strength of the end joints (5th percentile with 75% confidence) shall be equal to or greater than 2.1 times the ASD tension design value in the U.S. or 1.1 times the LSD specified tensile strength in Canada of the laminating lumber or SCL.
- c. A minimum of 5 individual end-joint specimens shall be selected and tested for bond durability. Each specimen shall have a length of approximately 6 inches (152 mm) with the end joint located approximately in the center of the specimen. The specimen shall be crosscut through the center of the joint with a saw kerf of 1/8 inch (3.2 mm)

or less to create two specimens with a length of approximately 3 inches (76 mm) and each having at least 1/4 inch (6.4 mm) of the end joint remaining after crosscutting. The specimens shall be tested for bond durability in accordance with the method in 8.2.6(b) and shall meet the delamination requirements specified in 6.3.3(b).

### **6.3.3 Edge and face joints between laminations**

- a. The wood failure of the edge (when required for structural performance) and face joints in the block shear specimens (see Figure 4) prepared in accordance to 8.2.4 and tested in accordance to 8.2.5 shall meet the following requirements:
  1. The average wood failure of all specimens combined shall equal to or greater than 80%,
  2. At least 95% of all specimens shall have a wood failure of minimum 60%, and
  3. For specimens with wood failure below 50%, a second block shear specimen shall be permitted to be prepared from the same bond line and tested in accordance with 8.2.5. Wood failure of the second specimen shall be 80% minimum.
- b. The delamination for the edge (when required for structural performance) and face joints in the delamination specimens (see Figure 5) prepared in accordance with 8.2.4 and tested in accordance with 8.2.6 shall meet the following requirements:
  1. The average delamination of all bond lines in each specimen shall not exceed 5%, and
  2. If the average delamination of all bond lines in a specimen exceeds 5% but is not more than 10%, a second delamination specimen shall be permitted to be prepared from the same CLT panel and tested in accordance with 8.2.6. The average delamination of all bond lines in the second specimen shall be no more than 5%.

For CLT products using SCL laminations, the SCL-to-lumber and SCL-to-SCL face bonds shall be permitted to be evaluated in accordance with the short-span flatwise bending tests specified in Section A4.2 of ASTM D5456 except that a single vacuum-pressure-soak cycle shall be permitted, and the average strength retention shall be at least 75%.

## 7 CLT PERFORMANCE CRITERIA

CLT shall meet the performance requirements established in this section.

### 7.1 CLT Grade and Layup Requirements

CLT grades and layups shall be specified in the manufacturing standard of each CLT plant when qualified in accordance with the requirements specified in this section and by an *approved agency*. Each custom CLT grade shall have unique designation assigned by the *approved agency*.

#### 7.1.1 Basic CLT Grades and Layups

Basic CLT grades and layups are those provided in Annex A.

*Note 17: As illustrated in Tables A2 and A4, the basic CLT grades and layups are balanced and symmetrical about the neutral axis, with alternating layers of the same lamination thickness.*

#### 7.1.2 Custom CLT Grades and Layups

CLT grades and layups that are not listed in Annex A shall be considered as custom grades and layups. Custom CLT grades and layups shall be permitted when approved by an *approved agency* in accordance with the qualification and mechanical test requirements specified in 8.4 and 8.5.

*Note 18: Custom CLT grades and layups may be asymmetric, contain different lamination thicknesses, and have adjacent layers oriented in the same direction.*

### 7.2 Structural Performance Requirements

Design values for each CLT grade and layup shall be developed using an engineering model recognized by an *approved agency* and shall be evaluated and confirmed by test results in accordance with 8.4 and 8.5.

*Note 19: Design values for basic CLT grades and layups are provided in Table A2 for use in the U.S. and Table A4 for use in Canada based on the engineering model shown in Appendix X3.*

### 7.3 Appearance Classifications

CLT panel appearance shall be as agreed upon between the end-user and the CLT manufacturer.

*Note 20: Appendix X1 contains examples of CLT appearance classifications for reference.*

## 8 QUALIFICATION AND PRODUCT MARKING

### 8.1 Qualification Requirements

Required qualification tests for CLT components, such as lumber, SCL, adhesives, and end, face, and edge joints are provided in Section 6 and summarized in Table 1. This section provides requirements for plant qualification and CLT qualification tests to meet the structural performance levels specified in Tables A2 and A4.

TABLE 1

SUMMARY OF QUALIFICATION REQUIREMENTS

Qualification for	Standard(s)	Referenced Section(s) in This Standard
Lumber	Grading Rules/Manufacturing Standard	6.1.1, 6.1.2, 6.1.4 through 6.1.7
SCL	ASTM D5456	6.13
Adhesives	This standard	6.2
End Joints	This standard	6.3.2 and 8.2.6(b)
Face Joints	This standard	6.1.6, 6.1.7, 6.3.3, 8.2, and 8.3
Edge Joints (if applicable)	This standard	6.1.8, 6.3.3, and 8.2
CLT Panel Dimensions	This standard	5
CLT Panel Structural Performance	ASTM D198 or ASTM D4761	7.2 and 8.5

### 8.2 Plant Pre-Qualification

#### 8.2.1 General

The CLT plant shall be pre-qualified for the manufacturing factors considered (see 8.2.2) using full-thickness qualification panels of 24 inches (610 mm) or more in the major strength direction and 18 inches (457 mm) or more in the minor strength direction (hereafter referred to as “pre-qualification panels”). A minimum of two replicate CLT pre-qualification panels shall be manufactured for pre-qualification for each combination of factors considered in 8.2.2. The two replicate CLT pre-qualification panels shall not be extracted from a single billet.

**Note 21:** A pre-qualification panel of 24 inches (610 mm) or more in the minor strength direction is recommended, particularly for thicker CLT products.

Pre-qualification panels shall be prepared at the facility or at an alternative facility acceptable to the *approved agency*. All pre-qualification panels shall be:

- a. Of the same approximate length and width at the time of pressing;
- b. Pressed individually; and
- c. Taken from approximately the geometric center of the larger panel, if applicable.



### 8.2.2 Fabrication of pre-qualification panels

Application of pressure to manufacture pre-qualification panels shall reflect the key characteristics of the manufacturing equipment, including the platen and glue spreader (as applicable) that is or will be used in the facility to be qualified. The applicability of the results shall be documented by the *approved agency*.

**Note 22:** For example, pre-qualification panels for facilities using a vacuum press or an air bag should be clamped using a vacuum press or an air bag inserted between the specimen and the rigid platen. In addition, the specimen preparation facility should distinguish between, for example, roller versus curtain coating and single spread versus double spread, which varies in the uniformity of the adhesive spread.

Factors considered for pre-qualification evaluation shall include assembly time, lamination moisture content, adhesive spread rate, clamping pressure, and wood surface temperature, as specified in the manufacturing standard of the plant and accepted by the *approved agency*.

### 8.2.3 Conditioning of pre-qualification panels

Pre-qualification panels shall be stored in an indoor environment for a minimum of 24 hours or until the adhesive has cured sufficiently to permit evaluation, whichever is longer.

**Note 23:** For panels larger than the specified pre-qualification panel size, the panels may be trimmed to the specified size to facilitate conditioning.

### 8.2.4 Specimens

A minimum of six square/rectangular specimens (three for block shear tests, i.e., “B” specimens and three for delamination tests, i.e., “D” specimens) shall be extracted from each pre-qualification panel at the locations shown in Figure 3 and labeled to indicate the panel number and the specimen position within the panel. The block shear “B” specimens and delamination “D” specimens shall be prepared in such a way that all laminations in the major strength direction are continuous (i.e. do not include an edge joint between laminations). In the minor strength direction, a maximum of one edge joint between laminations shall be allowed in each specimen. To meet this specimen requirement, additional “B” and “D” specimens shall be considered in the specimen preparation.

The “B” and “D” specimens shall be prepared in accordance with the test specimen configuration shown in Figures 4 and 5, respectively. If the pre-qualification panel is larger than the specified pre-qualification panel size, the pre-qualification sampling area shall be 24 inches (610 mm) to 36 inches (910 mm) square located at the geometric center of the panel.

FIGURE 3

**BLOCK SHEAR (“B”) AND DELAMINATION (“D”) SPECIMEN LOCATIONS**

$a = 4 \pm 1$  inches,  $L_1 = 24$  to  $36$  inches, and  $L_2 = 24$  to  $36$  inches (1 inch = 25.4 mm)

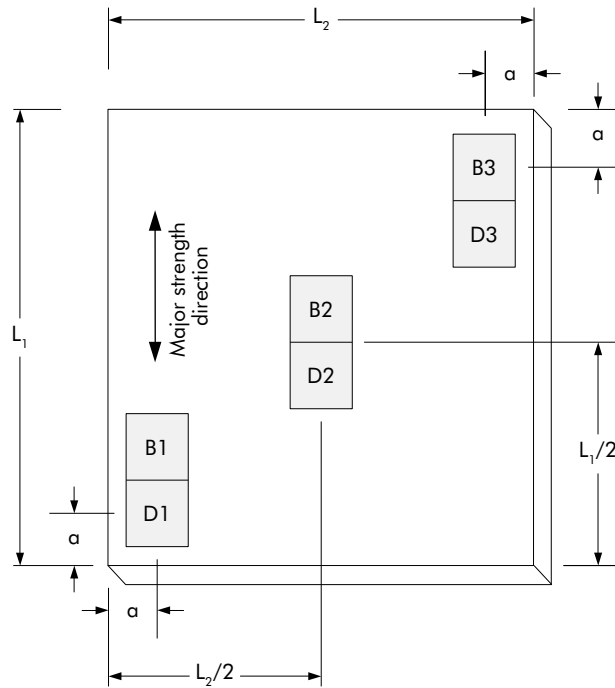
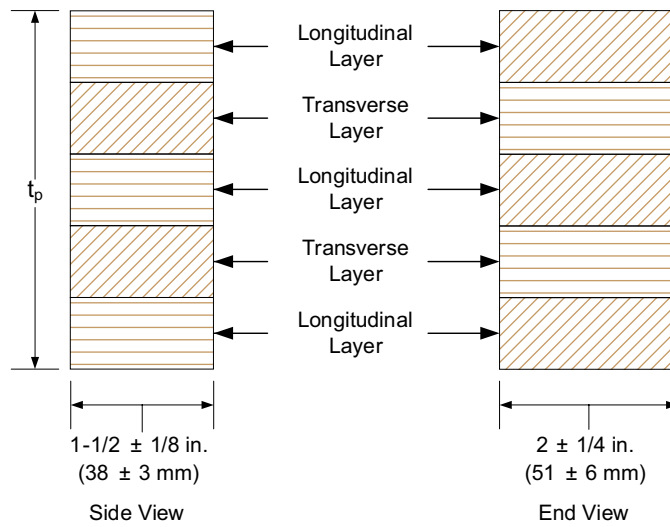

FIGURE 4

**STRAIGHT-BLOCK SHEAR SPECIMEN CONFIGURATION (5-PLY CLT SHOWN)**



Shear specimen configurations conforming to Figure A, B, or D of AITC Test T107 or Figure 1 of CSA 0177 are deemed to comply

FIGURE 5

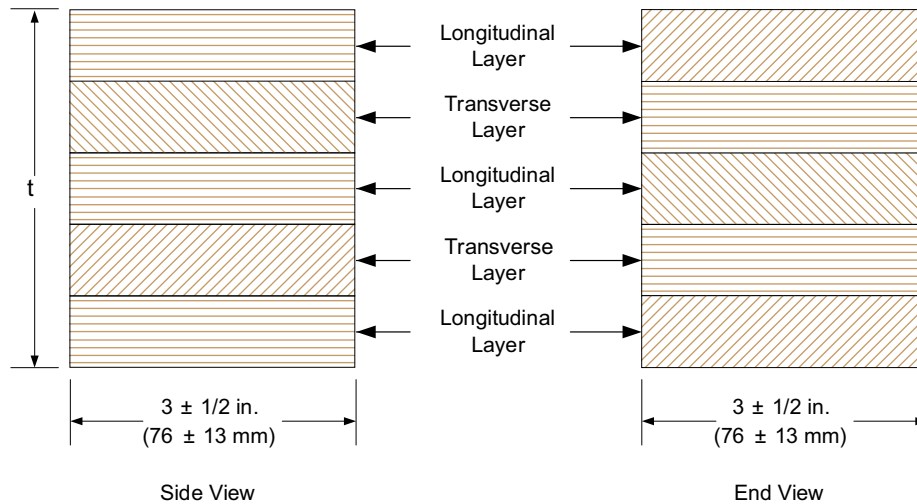
**DELAMINATION SPECIMEN CONFIGURATION (5-PLY CLT SHOWN)**

See 8.2.4 for permissible edge joints in the minor strength direction

**8.2.5 Shear tests**

- a. The block shear specimens obtained in accordance with 8.2.4 shall be subjected to the shear test specified herein and meet the wood failure requirements specified in 6.3.3.
- b. The block shear specimens shall be placed in a standard shearing tool and tested in shear by compression loading at a uniform rate of loading of  $0.50 \pm 0.05$  inch/min ( $12.7 \pm 1$  mm/min). The specimen shall be positioned in the shearing tool with the bond line in the shearing plane.

**Note 24:** A shearing tool for testing block shear specimens in shear by compression loading is described in ASTM D905. The ASTM D905 shear block test is intended for the assessment of adhesive bonds in wood products with bonded layers parallel to each other and with the grain oriented in the same direction, such as glulam. In the case of CLT, one half of the specimen is compressed parallel to the grain, which may produce longitudinal shear along the bond line, while the other half is compressed perpendicular to the grain, which may produce rolling shear along the shear plane. It is likely that the half of the specimen loaded perpendicular to the grain undergoes substantial deformation during the test, which may lead to crushing or tensile rupture perpendicular to the grain (peeling). These complications make interpretation of the shear block test on CLT specimens challenging and are likely to increase uncertainties related to the determination of wood failure fraction values. Therefore, it is important to include the description of the failure mode(s) in the test report.

### 8.2.6 Cyclic Delamination Test

- a. The delamination specimens obtained in accordance with 8.2.4 shall be subjected to the cyclic delamination test specified herein and meet the delamination requirements specified in 6.3.3(b).
- b. The initial weight of the delamination specimens shall be measured to the nearest gram and recorded prior to placing the specimens in an autoclave or similar pressure vessel that can safely withstand a minimum of 75 psi (517 kPa) of pressure. The specimens shall be weighted down and covered with water at a temperature of 65 to 85 °F (18 to 29 °C). A vacuum of 10 to 12 psi (69 to 85 kPa, which is equivalent to 20 to 25 inches or 510 to 640 mm Hg) shall be drawn and held for 30 minutes. The vacuum shall then be released and a pressure of  $75 \pm 5$  psi ( $517 \pm 34$  kPa) shall be applied for 2 hours. The specimens shall be removed from the autoclave and dried in a drying oven with forced air circulation at a temperature of approximately 160°F (71°C) until their weight is approximately between 110% and 115% of their original weight. During drying, the specimens shall be spaced at approximately 2 inches (50 mm) apart and with their end-grain surfaces parallel to the direction of the air flow. After drying to 110% to 115% of their initial weight, the specimens shall be removed from the oven, and delamination measured immediately and recorded.

## 8.3 Qualification of Effective Bond Area

### 8.3.1 General

The manufacturer shall establish visual grading rules for the bonded faces and limit the average glue skip to maintain an average effective bond area of 80% or more. The manufacturer's visual grading rules established to achieve the effective bond area shall include major visual characteristics, such as wane, knots, decay, pitch pockets, torn grain, and raised grain, based on characteristic measurements consistent with standard lumber grading rules.

### 8.3.2 Sample selection and inspection

Samples shall be drawn from representative production of laminations meeting the manufacturer's visual grading rules and positioned in accordance with the in-plant manufacturing standard. The layer formed by the laminations shall be verified by the *approved agency* to provide an effective bond area of 80% or more over any randomly selected area not less than 48 inches (1,220 mm) by 48 inches (1,220 mm).

*Note 25: A template with a square opening, i.e., 48 inches (1,220 mm) by 48 inches (1,220 mm), may be used to facilitate inspection.*

## 8.4 Qualification for Structural Performance

Following plant pre-qualification, a representative sample of CLT panels shall be manufactured for qualification tests in accordance with 8.4.1 and 8.4.2. Depending on the number of CLT grades and layups intended for qualification, a qualification plan shall be developed and accepted by an *approved agency* in accordance with the requirements prescribed in this section.

### 8.4.1 Required mechanical property qualification

The flatwise bending and flatwise shear properties of CLT grades at extreme depths in both major and minor strength directions shall be tested in accordance with 8.5.3 and 8.5.4 to confirm the design values shown in Table A2 for use in the U.S. or Table A4 for use in Canada, or the design values approved by an *approved agency*.

### 8.4.2 Optional mechanical property qualification

When edgewise bending and edgewise shear properties are to be approved by an *approved agency*, qualification tests shall be conducted in accordance with 8.5.5 and 8.5.6, respectively.

## 8.5 Mechanical Property Qualification

The design values from required mechanical property qualification (8.4.1) and optional mechanical property qualification (8.4.2) shall be approved by an *approved agency* in accordance with this section.

### 8.5.1 Sampling

Test specimens, including the width of laminations, shall be representative of typical production and shall be sampled at the manufacturing facility by an *approved agency* using the layup intended for qualification. The sample size required for stiffness capacities shall be sufficient for estimating the population mean within 5% precision with 75% confidence, or 10 specimens, whichever is greater. In general, a sample size larger than 10 is needed when the coefficient of variation is greater than 13%. The sample size required for strength capacities shall be sufficient for estimating the characteristic value with 75% confidence in accordance with ASTM D2915.

*Note 26: Both flatwise and edgewise bending moment, and shear capacities in the U.S. and both flatwise and edgewise bending moment, and shear resistances in Canada may be affected by the lamination width used in the CLT manufacturing. A significant change in the lamination width from original qualification will require subsequent requalification in accordance with 8.6 and Table 2.*

### 8.5.2 Moisture conditioning

CLT specimens shall be stored in an indoor environment for a minimum of 24 hours or until the adhesive has cured sufficiently to permit evaluation, whichever is longer. The CLT specimens at the time of mechanical tests shall have an average moisture content of not less than 8%.

### 8.5.3 Flatwise bending properties

Flatwise bending stiffness and bending moment capacity (resistance) shall be evaluated in accordance with 8.5.3.1 and 8.5.3.2.

#### 8.5.3.1 Flatwise bending test methods

Flatwise bending tests shall be conducted in both major and minor strength directions in accordance with the third-point load method of Sections 4 through 12 of ASTM D198 or Section 8 of ASTM D4761 using the specimen width of not less than 12 inches (305 mm) and the on-center span equal to approximately 30 times the specimen depth for the tests in the major strength direction and approximately 18 times the specimen depth for the tests in the minor strength direction. The weight of the CLT panel is permitted to be included in the determination of the flatwise bending moment capacity (resistance).

#### 8.5.3.2 Flatwise bending qualification requirements

In the U.S. and Canada, the average flatwise bending stiffness determined from qualification tests shall equal or exceed the published flatwise bending stiffness  $[(EI)_{\text{eff},f,0}$  or  $(EI)_{\text{eff},f,90}]$ . In the U.S., the characteristic flatwise bending moment capacity determined from qualification tests shall equal or exceed the published ASD reference flatwise bending moment capacity  $[(F_b S)_{\text{eff},f,0}$  or  $(F_b S)_{\text{eff},f,90}]$  times 2.1. In Canada, the characteristic flatwise bending moment resistance determined from qualification tests shall equal or exceed the published LSD flatwise bending resistance  $[(f_b S)_{\text{eff},f,0}$  or  $(f_b S)_{\text{eff},f,90}]$  divided by 0.96.

### 8.5.4 Flatwise shear properties

Flatwise shear stiffness and capacity (resistance) shall be evaluated in accordance with 8.5.4.1 and 8.5.4.2.

#### 8.5.4.1 Flatwise shear test methods

Flatwise shear stiffness tests shall be conducted in both major and minor strength directions in accordance with Sections 45 through 52 of ASTM D198. Flatwise shear tests shall be conducted in both major and minor strength directions in accordance with the center-point load method of Sections 4 through 12 of ASTM D198 or Section 7 of ASTM D4761 using the specimen width of not less than 12 inches (305 mm) and the on-center span equal to 5 to 6 times the specimen depth. The bearing length shall be sufficient to avoid bearing failure, but not greater than the specimen depth. All specimens are to be cut to length with no overhangs allowed.

#### 8.5.4.2 Flatwise shear qualification requirements

In the U.S. and Canada, the average flatwise shear stiffness determined from qualification tests shall equal or exceed the published shear stiffness in flatwise bending  $[(GA)_{\text{eff},f,0}$  or  $(GA)_{\text{eff},f,90}]$ . In the U.S., the characteristic flatwise shear capacity determined from qualification tests shall equal or exceed the published ASD reference flatwise shear capacity  $(V_{s,0}$  or  $V_{s,90})$  times 2.1. In Canada, the characteristic flatwise shear resistance determined from qualification tests shall equal or exceed the published LSD flatwise shear resistance  $(v_{s,0}$  or  $v_{s,90})$  divided by 0.96.

### 8.5.5 Edgewise bending properties

If the manufacturer intends to publish edgewise bending properties, edgewise bending stiffness and bending moment capacity (resistance) shall be evaluated in accordance with 8.5.5.1 and 8.5.5.2. If the specimens are not pre-conditioned to a standard moisture content level prior to testing, which may not be feasible depending on the size of the test specimens, the calculated bending strength and stiffness shall be adjusted to the standard moisture content using the procedures given in ASTM D2915 for CLT made of lumber laminations or ASTM D5456 made of SCL laminations. The volume, creep and load duration effects of edgewise bending capacity (resistance) shall be evaluated in accordance with the principles of Sections 7.4.1 and 7.4.2 of ASTM D5456.

#### 8.5.5.1 Edgewise bending test methods

Bending tests shall be conducted edgewise in both major and minor strength directions in accordance with the third-point load method of Sections 4 through 12 of ASTM D198 or Section 6 of ASTM D4761 using the specimen depth of not less than 12 inches (305 mm) and the on-center span equal to approximately 18 times the specimen depth. The weight of the CLT panel is permitted to be included in the determination of the edgewise bending moment capacity (resistance).

#### 8.5.5.2 Edgewise bending qualification requirements

Separate qualification shall be conducted for each layup. In the U.S. and Canada, the average edgewise bending stiffness determined from qualification tests divided by the calculated gross moment of inertia ( $I_{e,0}$  or  $I_{e,90}$ ) shall equal or exceed the published edgewise bending modulus of elasticity ( $E_{e,0}$  or  $E_{e,90}$ ). In the U.S., the characteristic edgewise bending moment capacity determined from qualification tests shall equal or exceed the published ASD reference edgewise bending stress ( $F_{b,e,0}$  or  $F_{b,e,90}$ ) multiplied by the calculated gross edgewise section modulus ( $S_{e,0}$  or  $S_{e,90}$ ) and an adjustment factor of 2.1. In Canada, the characteristic edgewise bending moment resistance determined from qualification tests shall equal or exceed the published LSD specified edgewise bending strength ( $f_{b,e,0}$  or  $f_{b,e,90}$ ) multiplied by the calculated gross edgewise section modulus ( $S_{e,0}$  or  $S_{e,90}$ ) and divided by an adjustment factor of 0.96.

### 8.5.6 Edgewise shear properties

If the manufacturer intends to publish edgewise shear properties, edgewise shear stiffness and capacity (resistance) shall be evaluated in accordance with 8.5.6.1 and 8.5.6.2.

#### 8.5.6.1 Edgewise shear test methods

Edgewise shear stiffness tests shall be conducted in both major and minor strength directions in accordance with Sections 45 through 52 of ASTM D198. Edgewise shear capacity (resistance) tests shall be conducted in both major and minor strength directions in accordance with the full-scale test method specified in Annex A3 of ASTM D5456. The web thickness of the I-shaped cross section shall be the CLT thickness. The specimen shall contain at least one edge joint, as applicable, in the middle 1/3 of the specimen depth.

**Note 27:** Tests have demonstrated that reinforcing the specimens with flanges (creating I-shaped beams) is necessary for development of the shear failure mode. Conducting preliminary tests to confirm the failure mode is recommended prior to producing the entire batch of I-shaped test specimens. Tests have also demonstrated that it may not be possible to fail the 7-ply or thicker CLT beams in shear in both minor and major strength directions. High-capacity testing apparatus is needed in all cases.

### 8.5.6.2 Edgewise shear qualification requirements

Separate qualification shall be conducted for each layup. For use in the U.S. or Canada, the average edgewise shear stiffness determined from qualification tests divided by the CLT thickness ( $t_p$ ) shall equal or exceed the published modulus of rigidity (shear modulus) in edgewise bending ( $G_{e,0}$  or  $G_{e,90}$ ). In the U.S., the characteristic edgewise shear capacity determined from qualification tests shall equal or exceed the published ASD reference edgewise shear capacity ( $F_{v,e,0} t_p$  or  $F_{v,e,90} t_p$ ) multiplied by an adjustment factor of 2.1. In Canada, the characteristic edgewise shear resistance determined from qualification tests shall equal or exceed the published LSD edgewise shear resistance ( $f_{v,e,0} t_p$  or  $f_{v,e,90} t_p$ ) divided by an adjustment factor of 0.96.

## 8.6 Process Changes Qualification

Significant changes to the manufacturing process or facilities shall be subjected to subsequent qualification testing. The requirements of 8.2 through 8.5 shall be reapplied for significant changes listed or equivalent to that listed in Table 2.

TABLE 2

### SUBSEQUENT QUALIFICATION IN RESPONSE TO SIGNIFICANT CHANGES

Category	Applicable Sections	Material Change (examples)	Notes
A	8.2 through 8.5	<ul style="list-style-type: none"> <li>▪ Press equipment</li> <li>▪ Adhesive formulation class</li> <li>▪ Addition or substitution of species from a different species group</li> <li>▪ Changes to the visual grading rules that reduce the effective bond area or the effectiveness of the applied pressure (e.g., warp permitted)</li> </ul>	
B	8.2, 8.3	<ul style="list-style-type: none"> <li>▪ Other changes to the manufacturing process or component quality not listed above</li> <li>▪ Adhesive composition (e.g., fillers and extenders)</li> </ul>	Additional evaluation in accordance with 8.4 and 8.5 is at the discretion of the approved agency <sup>a</sup>
C	8.4, 8.5	<ul style="list-style-type: none"> <li>▪ Increase in billet width or length of more than 20%</li> </ul>	
D	8.5.3 and 8.5.5 as applicable	<ul style="list-style-type: none"> <li>▪ Increase in the net lamination width of more than 2 inches (51 mm) from the lamination width used in the product qualification in either major or minor CLT strength direction<sup>b</sup></li> </ul>	
E	8.5.4 and 8.5.6 as applicable	<ul style="list-style-type: none"> <li>▪ Decrease in the net lamination width of more than 2 inches (51 mm) from the lamination width used in the product qualification in either major or minor CLT strength direction<sup>b</sup></li> </ul>	

a. Changes involving two or more manufacturing parameters shall be considered for reevaluation in accordance with 8.4 and 8.5.

b. Lamination width shall comply with 6.1.4.



## 8.7 Mill Specification

Upon conformance with the requirements specified in this standard, a manufacturing specification or documentation unique to the product and mill shall be written based on product evaluation. This specification shall be used for quality assurance purposes by the manufacturer and the *approved agency*. Control values for quality assurance shall be established during product evaluation to ensure conformance to performance requirements in this standard.

## 8.8 Certification and Marking

### 8.8.1 Certification

CLT products represented as conforming to this standard shall bear the stamp or certificate of conformance of an *approved agency* which (1) either inspects the manufacturer or (2) has tested a random sampling of the finished products in the shipment being certified for conformance with this standard.

### 8.8.2 Product marking

CLT products represented as conforming to this standard shall be identified with marks containing the following information:

- a. CLT grade qualified in accordance with this standard;
- b. The CLT thickness or identification;
- c. The mill name or identification number;
- d. The *approved agency* name or logo;
- e. The symbol of “ANSI PRG 320” signifying conformance to this standard;
- f. Any manufacturer’s designations which shall be separated from the grade-marks or trademarks of the *approved agency* by not less than 6 inches (152 mm);
- g. “Top” stamp on the top face of custom CLT panels used for roof or floor if manufactured with an unbalanced layup; and
- h. A production lot number or job identification number as a means to trace the CLT product back to the production and quality control records at the manufacturing facility.

### 8.8.3 Frequency of marking

Non-custom and other required marks in this section shall be placed on standard products at intervals of 8 feet (2.4 m) or less along the longest dimension of the CLT panel in order that each piece cut from a longer piece will have at least one of each of the required marks.

#### 8.8.4 Custom products

For products manufactured to meet specific job specifications (custom products), the marking shall be permitted to contain information less than that specified in 8.8.2. However, custom products shall bear at least one mark containing the information specified in 8.8.2(c), (d), (e), and (h). In addition, custom products shall be accompanied by a certificate of conformance to this standard including all of the information listed in 8.8.2. When CLT products shipped to a job are to be cut later into several members for use in the structure, the frequency of marking required in 8.8.3 shall be followed.

#### 8.8.5 Voiding marks

CLT products originally marked as conforming to this standard but subsequently rejected as not conforming thereto shall have any reference to the standard obliterated or voided by the manufacturer.

*Note 28: This can be performed by blocking out the stamp with permanent black ink or light sanding.*

## 9 QUALITY ASSURANCE

### 9.1 Objectives

This section is intended for use with CLT products that have been qualified under this standard. The purpose of this section is to assure product quality by detecting changes in properties that may adversely affect the CLT performance. In all cases, the criteria to which the CLT products are tested shall be provided in the Mill Specification or equivalent document.

### 9.2 Process Control

On-going evaluation of the process properties listed in this section shall be performed to confirm that the CLT quality remains in satisfactory compliance to the product specification requirements. Sampling methods and quality assurance testing shall be documented in an in-plant manufacturing standard and approved by the *approved agency*. All processes and test records relevant to the production shall be retained based on the manufacturer's record retention policy and are subject to audit by the *approved agency*. Production shall be held pending results of the quality assurance testing on representative samples.

### 9.3 End, Face, and Edge Joints in Laminations

The lamination end joints, face joints, and edge joints (when applicable) shall be sampled and tested for ongoing quality assurance in accordance with Table 3 and meet the strength (required for end joints only), wood failure, and durability requirements specified herein. The sampling shall be well-spaced in each production shift to avoid sampling concentration in the production time. Special considerations for face bonding of the CLT panel as a whole are provided in 9.3.1 through 9.3.4.

TABLE 3

**SUMMARY OF OFFLINE TESTS – FOR DAILY REQUIREMENTS**

Test	Minimum Number of Specimens	Requirements	Referenced Section(s) in This Standard
Face and Edge Joints <sup>a,b,c</sup>	1 specimen per billet up to 4 specimens per production shift	Wood Failure	6.3.3(a) and 8.2.5
	1 specimen per billet up to 2 specimens per production shift	Delamination	6.3.3(b) and 8.2.6
End Joints <sup>a,c,d</sup>	1 specimen per 5,000 joints produced up to 8 specimens per production shift	Tensile Strength	6.3.2(b)
	1 specimen per production shift	Delamination	6.3.2(c)

a. For each adhesive, lamination type, and species combination used.

b. Edge joint daily tests are required only when the edge joint is a structural requirement.

c. For each production line.

d. All grades and widths shall be tested over time. In each shift, at least one specimen shall represent the highest grade and widest width produced during the shift.

### 9.3.1 Effective bonding area

Laminations shall be laid up to maintain an effective bonding area of not less than 80% on surfaces to be bonded for each bondline.

*Note 29: To maintain an effective bond area, lumber laminations in adjacent layers may need to be oriented such that the bark and pith faces of adjacent pieces are generally alternated.*

### 9.3.2 Lumber lamination grade limits

Grade limits intended to limit the amount of lumber lamination warp that will not be corrected upon application of pressure shall be qualified in accordance with 8.3.

### 9.3.3 Glue skip in the face bondline

The average glue skip in a face bondline shall not exceed the level established to maintain the effective bonding area specified in 9.3.1.

### 9.3.4 Additional consideration for face joints

Sampling of face joints for quality assurance shall consider the large bonding area for a typical CLT panel and avoid a constant location at all times. Core shear specimens based on AITC Test T107 shall be permitted to be used in place of the block shear specimens specified in 8.2.4 and 8.2.5 for the quality assurance of face joints provided that a correlation factor between core shear and block shear specimens are evaluated in accordance with AITC Test T107 except that a minimum of 40 block shear specimens and an equal number of core shear specimens shall be tested. The correlation shall be documented and included in the in-plant manufacturing standard after the approval by the *approved agency*. The correlation factor shall be reevaluated at least annually.

### **9.3.5 Additional consideration for end joints**

For each production line, sampling of end joints shall include all grades and widths of laminations over time for each adhesive, lamination type, and species combination used. Each combination of grade, width, adhesive, lamination type, and species combination shall be tracked separately for quality assurance. For each production line, at least one end joint tested for each shift shall represent the highest grade and widest width for each adhesive, lamination type, and species combination produced during the shift.

## **9.4 Finished Production Inspection**

All production shall be inspected visually, and/or by measurements or testing for conformance to this standard with the following attributes:

- a. Dimensions (width, depth and length);
- b. Shape, including straightness and squareness;
- c. Type, quality and location of structural bond lines;
- d. Appearance classification;
- e. Layup, including lumber species and grades, placement, and orientation;
- f. Moisture content; and
- g. Application of the appropriate marks.

## **9.5 Minor Variations**

A product is considered conforming to this standard when minor variations of a limited extent in non-critical locations exist, or when structural damage or defects have been repaired and, in the judgment of a qualified person, the product is structurally adequate for the use intended. The identity of the product and the nature of the minor variation shall be documented and provided to the engineer of record upon request. A qualified person is one who is familiar with the job specifications and applicable design requirements and has first-hand knowledge of the manufacturing process.

## ANNEX A. Design Properties for PRG-320 CLT (Mandatory)

This Annex provides the design properties for basic CLT grades and layups listed in Table A2 using the lamination design values provided in Table A1. The CLT grades and layups represent the CLT production intended for use by the CLT manufacturers in North America and are based on the following:

- E1: 1950f-1.7E Spruce-pine-fir MSR lumber in all longitudinal layers and No. 3 Spruce-pine-fir lumber in all transverse layers
- E2: 1650f-1.5E Douglas fir-Larch MSR lumber in all longitudinal layers and No. 3 Douglas fir-Larch lumber in all transverse layers
- E3: 1200f-1.2E Eastern Softwoods, Northern Species, or Western Woods MSR lumber in all longitudinal layers and No. 3 Eastern Softwoods, Northern Species, or Western Woods lumber in all transverse layers
- E4: 1950f-1.7E Southern pine MSR lumber in all longitudinal layers and No. 3 Southern pine lumber in all transverse layers
- E5: 1650f-1.5E Hem-fir MSR lumber in all longitudinal layers and No. 3 Hem-fir lumber in all transverse layers
- V1: No. 2 Douglas fir-Larch lumber in all longitudinal layers and No. 3 Douglas fir-Larch lumber in all transverse layers
- V1(N): No. 2 Douglas fir-Larch (North) lumber in all longitudinal layers and No. 3 Douglas fir-Larch (North) lumber in all transverse layers
- V2: No. 1/No. 2 Spruce-pine-fir lumber in all longitudinal layers and No. 3 Spruce-pine-fir lumber in all transverse layers
- V3: No. 2 Southern pine lumber in all longitudinal layers and No. 3 Southern pine lumber in all transverse layers
- V4: No. 2 Spruce-pine-fir South lumber in all longitudinal layers and No. 3 Spruce-pine-fir South lumber in all transverse layers
- V5: No. 2 Hem-fir lumber in all longitudinal layers and No. 3 Hem-fir lumber in all transverse layers
- S1: 2250f-1.5E Laminated Veneer Lumber (LVL) in all longitudinal and transverse layers
- S2: 1900f-1.3E Laminated Strand Lumber (LSL) in all longitudinal and transverse layers
- S3: 1750f-1.3E Oriented Strand Lumber (OSL) in all longitudinal and transverse layers

TABLE A1  
**ASD REFERENCE DESIGN VALUES<sup>a</sup> FOR LAMINATIONS USED IN BASIC CLT GRADES (FOR USE IN THE U.S.)**

CLT Grade	Laminations Used in Major Strength Direction					Laminations Used in Minor Strength Direction						
	F <sub>b</sub> (psi)	E <sup>(b)</sup> (10 <sup>6</sup> psi)	F <sub>t</sub> (psi)	F <sub>c</sub> (psi)	F <sub>v</sub> (psi)	F <sub>s</sub> (psi)	F <sub>b</sub> (psi)	E <sup>(b)</sup> (10 <sup>6</sup> psi)	F <sub>t</sub> (psi)	F <sub>c</sub> (psi)	F <sub>v</sub> (psi)	F <sub>s</sub> (psi)
E1	1,950	1.7	1,375	1,800	135	45	500	1.2	250	650	135	45
E2	1,650	1.5	1,020	1,700	180	60	525	1.4	325	775	180	60
E3	1,200	1.2	600	1,400	110	35	350	0.9	150	475	110	35
E4	1,950	1.7	1,375	1,800	175	55	450	1.3	250	725	175	55
E5	1,650	1.5	1,020	1,700	150	50	500	1.2	300	725	150	50
V1	900	1.6	575	1,350	180	60	525	1.4	325	775	180	60
V1(N)	850	1.6	500	1,400	180	60	475	1.4	300	825	180	60
V2	875	1.4	450	1,150	135	45	500	1.2	250	650	135	45
V3	750	1.4	450	1,250	175	55	450	1.3	250	725	175	55
V4	775	1.1	350	1,000	135	45	450	1.0	200	575	135	45
V5	850	1.3	525	1,300	150	50	500	1.2	300	725	150	50
S1	2,250	1.5	1,500	1,950	130	40	2,250	1.5	1,500	1,950	130	40
S2	1,900	1.3	1,300	1,650	150	50	1,900	1.3	1,300	1,650	150	50
S3	1,750	1.3	1,200	1,500	115	35	1,750	1.3	1,200	1,500	115	35

For SI: 1 psi = 0.006895 MPa

- a. The ASD reference design values for laminations in the basic CLT grades made of visually graded lumber are based on 2x12 lumber. Because the basic CLT grades do not limit the lamination sizes used, the ASD reference design values for laminations in basic CLT grades are not increased for the lamination size, repetitive member, and flat use adjustment factors when calculating the ASD reference design properties for basic CLT grades provided in Table A2.
- b. The tabulated E values are published E for lumber and flatwise (plank) apparent E for SCL.

The ASD reference design capacities for the basic CLT grades with 3, 5, and 7 layers are provided in Table A2. These capacities were derived analytically using the Shear Analogy Model<sup>1</sup> (the calculated moment capacities in the major strength direction were further multiplied by a factor of 0.85 for conservatism) and validated by testing. The lamination thicknesses are as tabulated. The ASD reference tensile and compressive capacities will be developed and added to future editions of this standard.

1. Gagnon, S. and M. Popovski. 2011. *Structural Design of Cross-Laminated Timber Elements*. In: Chapter 3, *CLT Handbook*. FPIInnovations, Canada

TABLE A2  
**ASD REFERENCE DESIGN VALUES<sup>a</sup> FOR BASIC CLT GRADES AND LAYOUTS (FOR USE IN THE U.S.)**

CLT Grade	Lamination Thickness (in.) in CLT Layout						Major Strength Direction			Minor Strength Direction				
	$t_p$ (in.)	=	⊥	=	⊥	=	$(F_s)_{eff,0}$ (lb-ft/ft of width)	$(EI)_{eff,0}$ ( $10^6$ lb-ft <sup>2</sup> /in. <sup>2</sup> /ft of width)	$(GA)_{eff,0}$ ( $10^6$ lb-ft/ft of width)	$V_{s,0}$ (lb-ft/ft of width)	$(F_s)_{eff,90}$ (lb-ft/ft of width)	$(EI)_{eff,90}$ ( $10^6$ lb-ft <sup>2</sup> /in. <sup>2</sup> /ft of width)	$(GA)_{eff,90}$ ( $10^6$ lb-ft/ft of width)	$V_{s,90}$ (lb-ft/ft of width)
E1	4 1/8	=	⊥	=	⊥	=	4,525	115	0.46	1,490	160	3.1	0.61	495
	6 7/8	=	⊥	=	⊥	=	10,400	440	0.92	2,480	1,370	81	1.2	1,490
E2	9 5/8	=	⊥	=	⊥	=	18,375	1,089	1.4	3,475	3,150	313	1.8	2,480
	4 1/8	=	⊥	=	⊥	=	3,825	102	0.53	1,980	165	3.6	0.56	660
E3	6 7/8	=	⊥	=	⊥	=	8,825	389	1.1	3,300	1,440	95	1.1	1,980
	9 5/8	=	⊥	=	⊥	=	15,600	963	1.6	4,625	3,300	364	1.7	3,300
E4	4 1/8	=	⊥	=	⊥	=	2,800	81	0.35	1,160	110	2.3	0.44	385
	6 7/8	=	⊥	=	⊥	=	6,400	311	0.69	1,930	955	61	0.87	1,160
E5	9 5/8	=	⊥	=	⊥	=	11,325	769	1.0	2,700	2,210	234	1.3	1,930
	4 1/8	=	⊥	=	⊥	=	4,525	115	0.50	1,820	140	3.4	0.62	605
V1	6 7/8	=	⊥	=	⊥	=	10,400	440	1.0	3,025	1,230	88	1.2	1,820
	9 5/8	=	⊥	=	⊥	=	18,400	1,089	1.5	4,225	2,850	338	1.9	3,025
V2	4 1/8	=	⊥	=	⊥	=	3,825	101	0.46	1,650	160	3.1	0.55	550
	6 7/8	=	⊥	=	⊥	=	8,800	389	0.92	2,750	1,370	81	1.1	1,650
V1(N)	9 5/8	=	⊥	=	⊥	=	15,575	962	1.4	3,850	3,150	312	1.7	2,750
	4 1/8	=	⊥	=	⊥	=	2,090	108	0.53	1,980	165	3.6	0.59	660
V2	6 7/8	=	⊥	=	⊥	=	4,800	415	1.1	3,300	1,440	95	1.2	1,980
	9 5/8	=	⊥	=	⊥	=	8,500	1,027	1.6	4,625	3,300	364	1.8	3,300
V1(N)	4 1/8	=	⊥	=	⊥	=	1,980	108	0.53	1,980	150	3.6	0.59	660
	6 7/8	=	⊥	=	⊥	=	4,550	415	1.1	3,300	1,300	95	1.2	1,980
V2	9 5/8	=	⊥	=	⊥	=	8,025	1,027	1.6	4,625	3,000	364	1.8	3,300
	4 1/8	=	⊥	=	⊥	=	2,030	95	0.46	1,490	160	3.1	0.52	495
V1(N)	6 7/8	=	⊥	=	⊥	=	4,675	363	0.91	2,480	1,370	81	1.0	1,490
	9 5/8	=	⊥	=	⊥	=	8,275	898	1.4	3,475	3,150	312	1.6	2,480

Table continued on next page.

TABLE A2 (continued)  
**ASD REFERENCE DESIGN VALUES<sup>a</sup> FOR BASIC CLT GRADES AND LAYOUTS (FOR USE IN THE U.S.)**

CLT Grade	Lamination Thickness (in.) in CLT Layout						Major Strength Direction			Minor Strength Direction					
	$t_p$ (in.)	=	⊥	=	⊥	=	$(F_b S)_{eff,0}$ (lb-ft/ft of width)	$(EI)_{eff,0}$ (10 <sup>6</sup> lb-ft <sup>2</sup> /ft of width)	$(GA)_{eff,0}$ (10 <sup>6</sup> lb/ft of width)	$V_{90}$ (lb-ft/ft of width)	$(F_b S)_{eff,90}$ (lb-ft/ft of width)	$(EI)_{eff,90}$ (10 <sup>6</sup> lb-ft <sup>2</sup> /ft of width)	$(GA)_{eff,90}$ (10 <sup>6</sup> lb/ft of width)	$V_{90}$ (lb-ft/ft of width)	
V3	4 1/8	1 3/8	1 3/8	1 3/8	[REDACTED]			1,740	95	0.49	1,820	140	3.4	0.52	605
	6 7/8	1 3/8	1 3/8	1 3/8				1 3/8	4,000	363	0.98	3,025	1,230	88	1.0
V4	9 5/8	1 3/8	1 3/8	1 3/8	1 3/8	1 3/8	7,100	899	1.5	4,225	2,825	338	1.6	3,025	
	4 1/8	1 3/8	1 3/8	1 3/8	[REDACTED]			1,800	74	0.38	1,490	140	2.6	0.41	495
6 7/8	1 3/8	1 3/8	1 3/8	1 3/8				4,150	285	0.76	2,480	1,230	68	0.82	1,490
V5	9 5/8	1 3/8	1 3/8	1 3/8	1 3/8	1 3/8	7,325	706	1.1	3,475	2,825	260	1.2	2,480	
	4 1/8	1 3/8	1 3/8	1 3/8	[REDACTED]			1,980	88	0.45	1,650	160	3.1	0.48	550
6 7/8	1 3/8	1 3/8	1 3/8	1 3/8				4,550	337	0.91	2,750	1,370	81	0.97	1,650
S1	9 5/8	1 3/8	1 3/8	1 3/8	1 3/8	1 3/8	8,025	835	1.4	3,850	3,150	312	1.5	2,750	
	4 1/2	1 1/2	1 1/2	1 1/2	[REDACTED]			6,225	132	0.61	1,440	845	5.1	0.61	480
7 1/2	1 1/2	1 1/2	1 1/2	1 1/2				14,325	506	1.2	2,400	7,325	132	1.2	1,440
S2	10 1/2	1 1/2	1 1/2	1 1/2	1 1/2	1 1/2	25,325	1,252	1.8	3,350	16,850	506	1.8	2,400	
	4 1/2	1 1/2	1 1/2	1 1/2	[REDACTED]			5,250	114	0.53	1,800	715	4.4	0.53	600
7 1/2	1 1/2	1 1/2	1 1/2	1 1/2				12,100	438	1.1	3,000	6,175	114	1.1	1,800
S3	10 1/2	1 1/2	1 1/2	1 1/2	1 1/2	1 1/2	21,400	1,085	1.6	4,200	14,225	438	1.6	3,000	
	4 1/2	1 1/2	1 1/2	1 1/2	[REDACTED]			4,850	114	0.53	1,260	655	4.4	0.53	420
7 1/2	1 1/2	1 1/2	1 1/2	1 1/2				11,150	438	1.1	2,100	5,700	114	1.1	1,260
	10 1/2	1 1/2	1 1/2	1 1/2	1 1/2	1 1/2	19,700	1,085	1.6	2,950	13,000	438	1.6	2,100	

For S1: 1 in. = 25.4 mm; 1 ft = 304.8 mm; 1 lb-ft = 4.448 N

a. This table represents the basic CLT grades and layouts that are not listed in this table shall be permitted in accordance with 7.1.2.

**Note A1:** The rounding rules in Table A2 are as follows:

$F_b S$  (lb-ft/ft) and  $V_s$  (lb-ft/ft) — Nearest 25 for values greater than 2,500, nearest 10 for values between 1,000 and 2,500, or nearest 5 otherwise.

EI (lb-ft-in.<sup>2</sup>/ft) and GA (lb-ft) — Nearest 10<sup>6</sup> for values greater than 10<sup>7</sup>, nearest 10<sup>5</sup> for values between 10<sup>6</sup> and 10<sup>7</sup>, or nearest 10<sup>4</sup> otherwise.



**TABLE A3  
LSD SPECIFIED STRENGTH AND MODULUS OF ELASTICITY<sup>a,b</sup> FOR LAMINATIONS USED IN BASIC CLT GRADES (FOR USE IN CANADA)**

CLT Grade	Laminations Used in Major Strength Direction						Laminations Used in Minor Strength Direction					
	$f_b$ (MPa)	$E^{(e)}$ (MPa)	$f_t$ (MPa)	$f_c$ (MPa)	$f_s$ (MPa)	$f_p$ (MPa)	$E^{(e)}$ (MPa)	$f_t$ (MPa)	$f_c$ (MPa)	$f_s$ (MPa)	$f_p$ (MPa)	
E1	28.2	11,700	15.4	19.3	1.5	0.50	9,000	3.2	9.0	1.5	0.50	
E2	23.9	10,300	11.4	18.1	1.9	0.63	10,000	2.1	7.3	1.9	0.63	
E3	17.4	8,300	6.7	15.1	1.3	0.43	6,500	2.0	5.2	1.3	0.43	
E5	23.9	10,300	11.4	18.1	1.6	0.53	10,000	3.2	9.2	1.6	0.53	
V1(N)	10.0	11,000	5.8	14.0	1.9	0.63	10,000	2.1	7.3	1.9	0.63	
V2	11.8	9,500	5.5	11.5	1.5	0.50	9,000	3.2	9.0	1.5	0.50	
V5	11.0	11,000	6.2	14.8	1.6	0.53	10,000	3.2	9.2	1.6	0.53	
S1	28.7	10,300	19.1	21.5	1.7	0.56	10,300	19.1	21.5	1.7	0.56	
S2	24.2	8,900	16.6	18.2	1.9	0.64	9,300	16.6	18.2	1.9	0.64	
S3	22.3	8,900	15.3	16.5	1.5	0.49	8,900	15.3	16.5	1.5	0.49	

For SI: 1 MPa = 145 psi

a. The LSD design values for laminations in the basic CLT grades made of visually graded and MSR lumber are based on 2x12 lumber except for the specified tensile strength made of MSR lumber. Because the basic CLT grades do not limit the lamination sizes used, the LSD design values for laminations in basic CLT grades are not increased for the lamination size and system factors in accordance with CSA O86 when calculating the LSD design properties for basic CLT grades provided in Table A4. The LSD specified tensile strength values for MSR lumber are based on 2x8 lumber and not permitted to be increased for the system factor in accordance with CSA O86 when calculating the LSD design properties for basic CLT grades provided in Table A4.

b. The tabulated E values are published E for lumber and flatwise (plank) apparent E for SCL.

For use in Canada, the LSD design resistances for basic CLT grades and layups are listed in Table A4 using the LSD design values for the laminations provided in Table A3. The LSD design resistances are not compatible with the ASD reference design capacities used in the U.S. Since there are no published LSD specified strength and modulus of elasticity for Southern pine and Spruce-pine-fir South lumber in Canada, the CLT Grades E4, V1, V3, and V4 are not listed in Tables A3 and A4.

TABLE A4  
**LSD STIFFNESS AND UNFACTORED RESISTANCE VALUES<sup>a</sup> FOR BASIC CLT GRADES AND LAYOUTS (FOR USE IN CANADA)**

CLT Grade	Lamination Thickness (mm) in CLT Layout				Major Strength Direction				Minor Strength Direction			
	$t_p$ (mm)	=	⊥	=	$(f_b)_{eff,0}$ (10 <sup>6</sup> N-mm/m of width)	$(EI)_{eff,0}$ (10 <sup>8</sup> N-mm <sup>2</sup> /m of width)	$(GA)_{eff,0}$ (10 <sup>6</sup> N/m of width)	$V_{s,0}$ (kN/m of width)	$(f_b)_{eff,90}$ (10 <sup>6</sup> N-mm/m of width)	$(EI)_{eff,90}$ (10 <sup>8</sup> N-mm <sup>2</sup> /m of width)	$(GA)_{eff,90}$ (10 <sup>6</sup> N/m of width)	$V_{s,90}$ (kN/m of width)
E1	105	35	35	35	42	1,088	7.3	35	1.40	32	9.1	12
	175	35	35	35	98	4,166	15	58	12	837	18	35
	245	35	35	35	172	10,306	22	82	29	3,220	27	58
E2	105	35	35	35	36	958	8.0	44	0.94	36	8.2	15
	175	35	35	35	83	3,674	16	74	8.2	930	16	44
	245	35	35	35	146	9,097	24	103	19	3,569	25	74
E3	105	35	35	35	26	772	5.3	30	0.92	23	6.4	10
	175	35	35	35	60	2,956	11	50	8.0	605	13	30
	245	35	35	35	106	7,313	16	70	18	2,325	19	50
E5	105	35	35	35	36	958	8.0	37	1.40	36	8.2	12
	175	35	35	35	83	3,674	16	62	12	930	16	37
	245	35	35	35	146	9,097	24	87	29	3,569	25	62
V1(N)	105	35	35	35	15	1,023	8.0	44	0.94	36	8.7	15
	175	35	35	35	35	3,922	16	74	8.2	930	17	44
	245	35	35	35	61	9,708	24	103	19	3,571	26	74
V2	105	35	35	35	18	884	7.2	35	1.4	32	7.5	12
	175	35	35	35	41	3,388	14	58	12	837	15	35
	245	35	35	35	72	8,388	22	82	29	3,213	23	58
V5	105	35	35	35	17	1,023	8.0	37	1.40	36	8.7	12
	175	35	35	35	38	3,922	16	62	12	930	17	37
	245	35	35	35	67	9,708	24	87	29	3,571	26	62
S1	114	38	38	38	51	1,226	8.9	43	6.90	47	8.9	14
	190	38	38	38	117	4,704	18	71	60	1,226	18	43
	266	38	38	38	207	11,647	27	99	138	4,704	27	71

Table continued on next page.

TABLE A4 (continued)  
**LSD STIFFNESS AND UNFACTORED RESISTANCE VALUES<sup>a</sup> FOR BASIC CLT GRADES AND LAYUPS (FOR USE IN CANADA)**

CLT Grade	t <sub>p</sub> (mm)	Lamination Thickness (mm) in CLT Layup						Major Strength Direction			Minor Strength Direction			
		=	⊥	=	⊥	=	⊥	(f <sub>b</sub> ) <sub>eff,t,0</sub> (10 <sup>6</sup> N-mm/m of width)	(EI) <sub>eff,t,0</sub> (10 <sup>6</sup> N-mm <sup>2</sup> /m of width)	(GA) <sub>eff,t,0</sub> (10 <sup>6</sup> N/m of width)	v <sub>s,0</sub> (kN/m of width)	(f <sub>b</sub> ) <sub>eff,t,90</sub> (10 <sup>6</sup> N-mm/m of width)	(EI) <sub>eff,t,90</sub> (10 <sup>6</sup> N-mm <sup>2</sup> /m of width)	(GA) <sub>eff,t,90</sub> (10 <sup>6</sup> N/m of width)
S2	114	38	38	38	38	38	43	1,059	7.7	49	5.80	41	7.7	16
	190	38	38	38	38	38	99	4,064	15	81	51	1,059	15	49
	266	38	38	38	38	38	175	10,064	23	113	116	4,064	23	81
S3	114	38	38	38	38	38	40	1,059	7.7	37	5.40	41	7.7	12
	190	38	38	38	38	38	91	4,064	15	62	47	1,059	15	37
	266	38	38	38	38	38	161	10,064	23	87	107	4,064	23	62

For SI: 1 mm = 0.03937 in.; 1 m = 3.28 ft; 1 N = 0.2248 lbf

a. This table represents the basic CLT grades and layups. Custom CLT grades and layups that are not listed in this table shall be permitted in accordance with 7.1.2.

**Note A2.** The rounding rules in Table A4 are as follows:

f<sub>b</sub>S (N-mm/m) and GA (N/m)—Nearest 10<sup>6</sup> for values greater than 10<sup>7</sup>, nearest 10<sup>5</sup> for values between 10<sup>6</sup> and 10<sup>7</sup>, or nearest 10<sup>4</sup> otherwise.

v<sub>s</sub> (kN/m)—Nearest 1 for values greater than 10, nearest 0.1 for values between 10 and 1, or nearest 0.01 otherwise.

EI (N-mm<sup>2</sup>/m)—Nearest 10<sup>9</sup> for values greater than 10<sup>10</sup>, nearest 10<sup>8</sup> for values between 10<sup>9</sup> and 10<sup>10</sup>, or nearest 10<sup>7</sup> otherwise.

## ANNEX B. Practice for Evaluating Elevated Temperature Performance of Adhesives Used in Cross-Laminated Timber Using the Compartment Fire Test (CFT) Method (Mandatory)

### B1 Scope

- B1.1** This annex is to be used to evaluate the elevated temperature performance of adhesives used in cross-laminated timber (CLT).
- B1.2** An unprotected CLT floor-ceiling slab is exposed to specified fire conditions representative of a real fire scenario.
- B1.3** The unprotected CLT floor-ceiling slab shall sustain the applied load during the specified fire exposure for a period of 240 minutes without char layer fall-off resulting in fire regrowth during the cooling phase of a fully developed fire.
- B1.4** This annex is used to evaluate the performance of adhesives used in CLT to heat and flame under controlled conditions, but does not by itself incorporate all factors required for fire hazard or fire risk assessment under actual fire conditions
- B1.5** This annex does not purport to address all of the safety concerns, if any, associated with its use. It is the responsibility of the user of this annex to establish appropriate safety and health practices and determine the applicability of regulatory limitations prior to use.

### B2 Referenced Documents

See Section 2 of the standard for referenced documents. Referenced standards specific to this annex are listed below.

ASTM C1396/C1396M-17 Standard Specification for Gypsum Board

*ASTM E176-15ae1 Standard Terminology of Fire Standards*

### B3 Terminology

#### B3.1 Definition

Definitions used in this annex are in accordance with Section 3 of the standard, and the terminology standards ASTM D9 and ASTM E176, unless otherwise indicated.

#### B3.2 Superimposed Load

The additional external load needed to be applied to the slab to result in the specified calculated stresses within the slab when any dead load of the assembly itself is accounted for in the calculations.

## B4 Summary of Practice

**B4.1** This annex shall be used to evaluate adhesives intended for use in CLT by fire testing a floor-ceiling slab under a vertical load associated with 25% of the effective ASD reference flatwise bending moment of the CLT. The unprotected CLT floor-ceiling slab shall sustain the applied load during the specified fire exposure for a period of 240 minutes without char layer fall-off resulting in a significant temperature increase at the compartment ceiling during the cooling phase of a fully developed fire. The temperature increase is considered significant if, after 150 minutes, any room interior thermocouple at the compartment ceiling exceeds 950 °F (510 °C) at any time before termination of the test.

## B5 Significance and Use

**B5.1** CLT used in fire-resistance-rated assemblies shall be able to support the superimposed design load for the specified time under the specified fire exposure without char layer fall-off resulting in fire regrowth during the cooling phase of a fully developed fire.

## B6 Sample Description

### B6.1 Dimensions

CLT floor-ceiling sample shall be approximately 8 feet by 16 feet (2438 mm by 4877 mm), with the long dimension spanning in the major strength direction. Clear distance between the supports shall be at least 15 feet (4572 mm).

### B6.2 Fabrication

CLT floor-ceiling test sample shall be at least 5-ply CLT with maximum lamination thickness of 1-3/8 inches (35 mm) and maximum lamination widths of 7-1/4 inches (184 mm). The edge joints in the laminations shall be tight, but shall not be edge-glued.

### B6.3 Adhesive

CLT floor-ceiling test sample shall be fabricated using the adhesive being evaluated.

### B6.4 Moisture Content

The moisture content of the CLT floor-ceiling test sample shall be not greater than the moisture content specified in Section 6.1.4 of this standard at the time of the fire test.

## B7 Test Room Description

### B7.1 Test Room Dimensions

A test room shall have interior dimensions of 9 feet ± 4 inches (2743 mm ± 102 mm) in width by 19 feet ± 4 inches (5791 mm ± 102 mm) in depth by 8 feet ± 2 inches (2438 mm ± 51 mm) in height. The test room shall consist of two sections separated by a protected beam across the width of the room, located at approximately 15 feet (4572 mm) from the interior of the front wall. The CLT floor-ceiling sample shall be located in the front section of the room. A propane or natural gas diffusion burner shall be used to create the exposing fire. The burner shall be located in the back section of the test room (referred to hereafter as the burner compartment).

*Note B1: A steel frame structure protected with three layers of 5/8-inch (15.9-mm) type X gypsum board conforming to ASTM C1396/C1396M and three layers of 6 pcf (96 kg/m<sup>3</sup>) ceramic fiber blanket (four layers of each in the back section) has been found suitable (see Appendix X2 for a detailed description of the test structure that was used in the development of the method described in this annex).*

### **B7.2 Floor–Ceiling Support**

The CLT floor-ceiling slab shall be supported across the full 8-foot (2438-mm) width of the room by the front wall at one end and by a protected beam at the other end. The beam shall be located at a sufficient distance from the front wall to result in a clear span of at least 15 feet (4572 mm). The remaining portion of the ceiling over the burner shall be protected.

### **B7.3 Front Wall**

The 8-foot (2438-mm) tall bearing wall at the front end of the room shall be capable of supporting the CLT floor-ceiling slab for the duration of the fire test.

### **B7.4 Back Wall**

The 8-foot (2438-mm) tall bearing wall at the back end of the room shall be capable of supporting the protected ceiling over the burner for the duration of the fire test.

### **B7.5 Non–Loadbearing Side Walls**

The 10-foot (3048 mm) tall, 19-foot (5791-mm) long side walls of the test room shall be capable of remaining in place without deflection for the duration of the fire test. A narrow gap along each of the side walls shall permit the floor-ceiling slab to deflect freely without contacting the side walls. The gap between the side wall and the CLT floor-ceiling slab shall be covered with ceramic fiber blanket to prevent smoke and hot gases from leaking and exposing the long edges of the CLT slab.

### **B7.6 Wall Opening Dimensions**

All four walls shall be enclosed except for a ventilation opening in the front 8-foot (2438-mm) wall, which shall have dimensions of  $36 \pm 2$  inches ( $914 \pm 51$  mm) in width by  $75 \pm 2$  inches ( $1905 \pm 51$  mm) in height.

### **B7.7 Protected Beam**

The beam shall be located  $15 \text{ feet} \pm 4 \text{ inches}$  ( $4572 \pm 102$  mm) from the interior of the front wall, and shall be capable of supporting the CLT floor-ceiling slab and the protected ceiling over the burner for the duration of the fire test.

### **B7.8 Burner Compartment**

The back part of the test room shall consist of a  $9 \text{ feet} \pm 4 \text{ inches}$  ( $2743 \text{ mm} \pm 102 \text{ mm}$ ) wide by  $7 \text{ feet} \pm 2 \text{ inches}$  ( $2134 \text{ mm} \pm 51 \text{ mm}$ ) high burner compartment, and shall be open to the front part of the test room where the CLT floor-ceiling slab is located. The burner compartment shall be protected to ensure that its walls and ceiling remain in place without deflection for the duration of the fire test.

## B8 Instrumentation

### B8.1 Hot Gas Layer (Ceiling) Thermocouples

Five 1/8-inch- (3.2-mm-) diameter exposed junction Inconel-sheathed type K thermocouples shall be located 4 inches (102 mm) below the ceiling in the following locations: at the center of the exposed ceiling and at the center of each of the four quadrants of the CLT floor-ceiling slab.

*Note B2:* To obtain an indication of the temperature evolution at the glue-lines, 1/16-inch- (1.6-mm-) diameter grounded junction Inconel-sheathed type K thermocouples can be inserted from the unexposed side of the CLT. Since the thermal exposure conditions vary somewhat between the front and the back of the test room, it is recommended that embedded thermocouples be installed at three locations along the long dimension of the CLT floor-ceiling slab, i.e., at the center and the quarter points of the clear span. It is further recommended that thermocouples be located at the bottom first, second, and third gluelines, and as far as possible from joints and edges. For example, for CLT made with 1-3/8-in- (35-mm-) thick laminations, the following thermocouple locations apply: 1.38, 2.75, and 4.13 inches (35, 70, and 105 mm) from the exposed side (bottom) of the CLT floor-ceiling slab. The measurement uncertainty of the embedded thermocouples is due to the error associated with the assumed depth at which the thermocouple is located, heat conduction along the thermocouple wires, the potential presence of gaps and/or local density variations (such as knots) in the vicinity of the thermocouple, etc. Consequently, the optional embedded thermocouple measurements are indicative, and are not part of the acceptance criteria.

**B8.2** Gaseous fuel shall be supplied to the burner at a time-varying rate to obtain the heat release rate profile established from calibration testing (see Section B10).

**B8.3** Temperatures and the fuel flow rate shall be recorded throughout the test.

## B9 Loading

**B9.1** The superimposed load on the CLT floor-ceiling slab shall result in 25% of the effective ASD reference flatwise bending moment.

## B10 Calibration Test Method

**B10.1** Calibration testing shall be conducted to determine the fuel flow rate for the qualification tests. The fuel flow rate shall provide an average temperature of the five ceiling thermocouple temperatures as shown in Figure B1. The time-temperature curve in Figure B1 is achieved by using a diffusion burner placed in the back of the test room, and by changing the burner fuel flow rate in steps at 0, 13, 38, 58, and 88 min. The average ceiling thermocouple temperature at those times shall be within the tolerances given in Table B1. The temperatures at other times in Table B1 are provided for guidance. In no case shall any ceiling thermocouple temperature drop more than 10% below the average of the recorded ceiling thermocouple temperatures.

**Note B3:** A burner consisting of a 2-by-6-by-1-foot- (610-by-1829-by-305-mm-) tall steel box with open top, filled with gravel and supplied with propane gas has been found suitable. See Appendix X2 for a detailed description of the burner that was used in the development of the method described in this annex.

**B10.2** The CLT floor-ceiling slab shall be protected from the bottom with three layers of 5/8-inch (15.9-mm) Type X gypsum wallboard conforming to ASTM C1396/C1396M. The gypsum wallboard shall be attached with Type S drywall screws every 12 inches (305 mm) o.c. with a minimum penetration into the wood of at least 1 inch (25.4 mm).

## **B11 Qualification Test Method**

**B11.1** The fuel flow rate determined in Section B10.1 shall be used for the qualification tests.

**B11.2** The unprotected CLT floor-ceiling slab, complying with Section B6, shall be tested for 240 minutes.

**Note B4:** If the CLT floor-ceiling slab clearly fails prior to 240 minutes, the test should be permitted to be terminated early.

## **B12 Acceptance Criteria**

**B12.1** The unprotected CLT floor-ceiling slab shall sustain the applied load during the specified fire exposure for a period of 240 minutes.

**B12.2** After 150 minutes, none of the ceiling thermocouples shall exceed 950 °F (510 °C).

## **B13 Report**

**B13.1** The report shall contain the following minimum information:

**B13.1.1** Description of the CLT floor-ceiling sample including the lamination species, lamination dimensions, slab thickness, and the manufacturer;

**B13.1.2** Adhesive manufacturer, adhesive type, and adhesive formulation identification;

**B13.1.3** Description of the test room construction;

**B13.1.4** Description of the loading method;

**B13.1.5** Results of the calibration test including the fuel flow rates and thermocouple data;

**B13.1.6** Time-temperature curve for the ceiling thermocouples; and

**B13.1.7** Visual observations during and after the test.



FIGURE B1

**CALIBRATION TIME-TEMPERATURE CURVE**

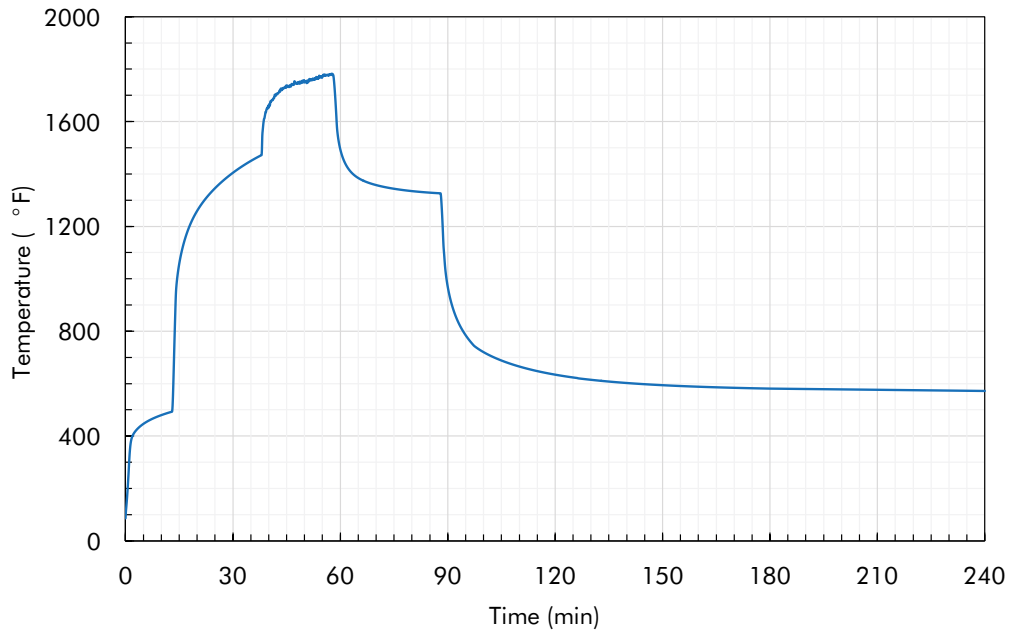

TABLE B1

**CALIBRATION TEMPERATURES AND TOLERANCES AT SPECIFIC TIMES**

Time (min.)	Temperature (°F)	Tolerance (°F)	Temperature (°C)	Tolerance (°C)
13	493	±36	256	±20
28	1383		751	
38	1472	±45	800	±25
48	1746		952	
58	1778	±54	970	±30
68	1366		741	
78	1338		725	
88	1326	±45	719	±25
120	634		335	
150	594		312	
180	581	±36	305	±20
240	572		300	

## APPENDIX X1. Examples of CLT Appearance Classifications (Non-Mandatory)

This appendix contains examples of CLT appearance classifications for CLT panels manufactured with lumber laminations for reference only. These requirements are based on the appearance at the time of manufacturing. The actual CLT panel appearance requirements are recommended to be agreed upon between the end-user and the CLT manufacturer.

### X1-1 Architectural Appearance Classification

An appearance classification normally suitable for applications where appearance is an important, but not overriding consideration. Specific characteristics of this classification are as follows:

- In exposed surfaces, all knot holes and voids measuring over 3/4 inch (19 mm) are filled with a wood-tone filler or clear wood inserts selected for similarity with the grain and color of the adjacent wood.
- The face layers exposed to view are free of loose knots and open knot holes are filled.
- Knot holes do not exceed 3/4 inch (19 mm) when measured in the direction of the lamination length with the exception that a void may be longer than 3/4 inch (19 mm) if its area is not greater than 1/2 in.<sup>2</sup> (323 mm<sup>2</sup>).
- Voids greater than 1/16 inch (1.6 mm) wide created by edge joints appearing on the face layers exposed to view are filled.
- Exposed surfaces are surfaced smooth with no misses permitted.

### X1-2 Industrial Appearance Classification

An appearance classification normally suitable for use in concealed applications where appearance is not of primary concern. Specific characteristics of this classification are as follows:

- Voids appearing on the edges of laminations need not be filled.
- Loose knots and knot holes appearing on the face layers exposed to view are not filled.
- Members are surfaced on face layers only and the appearance requirements apply only to these layers.
- Occasional misses, low laminations or wane (limited to the lumber grade) are permitted on the surface layers and are not limited in length.

## APPENDIX X2. Test Setup Used in the Development of Annex B (Non-Mandatory)

### X2-1 Introduction

This appendix provides a detailed description of the room that was used in the development of the test method described in Annex B.

### X2-2 Test Room

A test room was constructed with nominal interior dimensions 9 feet 4 inches (2845 mm) in width, 19 feet (5791 mm) in length, and 8 feet (2438 mm) in height. The ventilation opening in the front wall was nominally 36 inches (914 mm) in width by 75 inches (1905 mm) in height. The test room was built directly on the concrete floor of the laboratory, but the test room floor was protected with several layers of type X gypsum board. Drawings of the finished test room can be found in Figures X2-1 through X2-4. A detailed description follows.

Two steel I-beams of 12 inches (305 mm) in height and 41 lbf/foot (0.6 kN/m) by weight welded together were located at approximately 15 feet (4572 mm) from the front wall to subdivide the test room into two sections. The ceiling of the front section was left open and allowed for the exposure of a 16-foot- (4877-mm-) long by 8-foot- (2438-mm-) wide mass timber ceiling panel. The panel was simply supported by the front wall at one end (bearing length  $\approx$  6 inches or 152 mm), and by the steel I-beam at the other end (bearing length  $\approx$  5-1/4 inches or 133 mm). The sides of the panel were not supported, and the panel was allowed to deflect freely between the two side walls. A gas burner to create the desired fire exposure was located in the back section of the room, as shown in Figure X2-5. Construction details for the test room walls, floor and ceiling are as follows:

#### X2-2.1 Front Wall

The front wall of the test room consisted of 8-foot- (2438-mm-) tall and 6-inch- (152-mm-) deep, 16-gauge steel studs at 12 inches (305 mm) on center, and with 16-gauge track top and bottom. The interior surface of the frame was covered with three layers of 5/8-inch (15.9-mm) type X gypsum board (National Gypsum Fire-Shield®), 20-gauge galvanized sheet steel, and three layers of 1-inch- (25.4-mm-) thick ceramic fiber blanket (Morgan Thermal Ceramics 6 pcf or 96 kg/m<sup>3</sup> Cerablanket®). The exterior surface was covered with two layers of 5/8-inch (15.9-mm) type X gypsum board, 20-gauge galvanized sheet steel (top half only), and one layer of 1-inch- (25.4-mm-) thick ceramic fiber blanket (additional layers of blanket were used at the soffit and above the ventilation opening).

## **X2–2.2 Side Walls**

The side walls of the test room consisted of three layers of 4-foot- (1219-mm-) wide by 10-foot- (3048-mm-) tall 5/8-inch (15.9-mm) type X gypsum board attached to steel racks. The interior surface of the gypsum board was covered with three layers of 1-inch- (25.4-mm-) thick ceramic fiber blanket. An additional layer of blanket was attached to the side walls in the back section of the test room. In the front section of the test room, the web of a 6-inch- (152-mm-) deep steel stud covered with 16-gauge track was attached to the side walls at 8 feet (2438 mm) above the floor. The bottom of the covered studs was protected with three layers of 5/8-inch (15.9-mm) type X gypsum board. Two layers were used to protect the vertical and top surfaces. The studs and track mounted along the side walls were covered with four layers of ceramic fiber blanket to reduce the width of the opening in the front section of the test room from 9 feet 4 inches (2845 mm) to 8 feet 5 inches (2565 mm), as shown in Figure X2-5. The gaps along the edges of the panel were filled with ceramic fiber blanket, and the top and bottom of the gaps were then covered with a strip ceramic fiber blanket attached to the panel and a side wall of the test room, as shown in Figure X2-6.

## **X2–2.3 Back Wall**

The back wall of the test room consisted of 8-foot- (2440-mm-) tall, 3-5/8-inch- (92-mm-) deep, 18-gauge steel studs at 12 inches (305 mm) on center and with 18-gauge track top and bottom. The interior surface of the frame was covered with four layers of 5/8-inch (15.9-mm) type X gypsum board and three layers of 1-inch- (25.4-mm-) thick ceramic fiber blanket. The exterior surface was not finished. An opening at the bottom of the back wall allowed the 2-inch- (50.8-mm-) diameter propane pipe nipple from the burner to pass-through to connect to the supply hose outside the test room. The opening was sealed with ceramic fiber blanket.

## **X2–2.4 I-beams**

The space between the exposed surfaces of the flanges and web were filled with several layers of 5/8-inch (15.9-mm) type X gypsum board, and the beams were then wrapped with four layers of 1-inch- (25.4-mm-) thick ceramic fiber blanket.

## **X2–2.5 Back Section Ceiling**

The ceiling above the burner consisted of a spare 4.5-foot (1372-mm) by 8-foot (2438-mm) CLT panel, protected with four layers of 5/8-inch (15.9-mm) type X gypsum board and four layers of 1-inch- (25.4-mm-) thick ceramic fiber blanket. The front edge of the CLT panel was supported by one of the two I-beams. At the back edge, the CLT panel was attached to a 3-1/2-inch (89-mm) by 3-1/2-inch (89-mm) by 1/4-inch (6.4-mm) angle iron welded to the racks supporting the side walls.

Fastener details are as follows:

First layer of gypsum board: 1-7/8-inch (48-mm) #6 type S bugle head drywall screws.

Second layer of gypsum board: 2-1/2-inch (64-mm) #6 type S bugle head drywall screws.

Third and fourth layer of gypsum board: 3-inch (76-mm) #8 type S bugle head drywall screws.

First and second layer of ceramic fiber blanket: 4-1/2-inch (114-mm) coarse thread screws with 1-inch (25.4-mm) washers.

Third and fourth layer of ceramic fiber blanket: 12-gauge galvanized steel wire bent into horseshoe shape.

Screw spacing was approximately 12 inches (305 mm). Wires were used where needed. All joints were staggered with at least 1 foot (305 mm) separation.

## X2-3 Gas Burner

### X2-3.1 Burner Construction

A gas burner was constructed to create the exposing fire. The burner consisted of a 6-foot- (1829-mm-) long by 2-foot- (610-mm-) wide by 1-foot- (305-mm-) tall steel box with open top. Five pieces of 2-inch (51-mm) by 3-inch (76 mm) steel rectangle tube were welded to the bottom plate, elevating the burner approximately 2 inches (51 mm) above the floor (see Figure X2-5). The burner was supplied with propane through a 2-inch-(51-mm-) diameter pipe. The gas flow was evenly distributed to eight downward-facing release points as shown in Figure X2-7. The burner was filled with coarse gravel to ensure relatively uniform propane flow at the top surface (see Figure X2-5).

TABLE X2-1

#### BURNER HRR STEP PROFILE

Start (min.)	End (min.)	HRR (kW)
0	13	250
13	38	1075
38	58	1377
58	88	834
88	End of Test	250

### X2-3.2 Burner Heat Release Rate Profile

Propane was supplied from two tanks via a vaporizer, a regulator, and a 2-inch- (51-mm-) diameter pipe with several shut-off valves and a control valve. The propane flow rate was manually controlled, and measured with a Coriolis mass flow sensor. The burner profile is shown in Table X2-1 and Figure X2-8.

FIGURE X2-1

3-D VIEW OF TEST ROOM

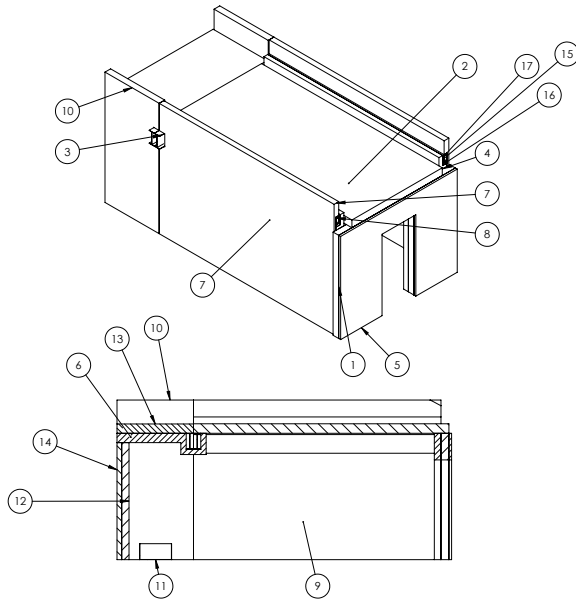

Item No.	Description	Quantity
1	Front wall	1
2	CLT panel	1
3	I beam 12 x 41	2
4	Front wall interior insulation	1
5	Front wall exterior insulation	1
6	Burner section ceiling insulation	1
7	Side wall CLT section	2
8	Sidewall studs and track	4
9	Sidewall stud insulation blanket	2
10	Burner section side wall	2
11	Burner	1
12	Burner section back wall	1
13	Burner section CLT panel	1
14	Burner section outside gyp	1
15	Sidewall stud-side gyp	2
16	Sidewall stud under gyp	2
17	Sidewall stud top gyp	2

FIGURE X2-2

PLAN VIEW AND SIDE ELEVATION (SECTION) OF TEST ROOM (Units in inches)

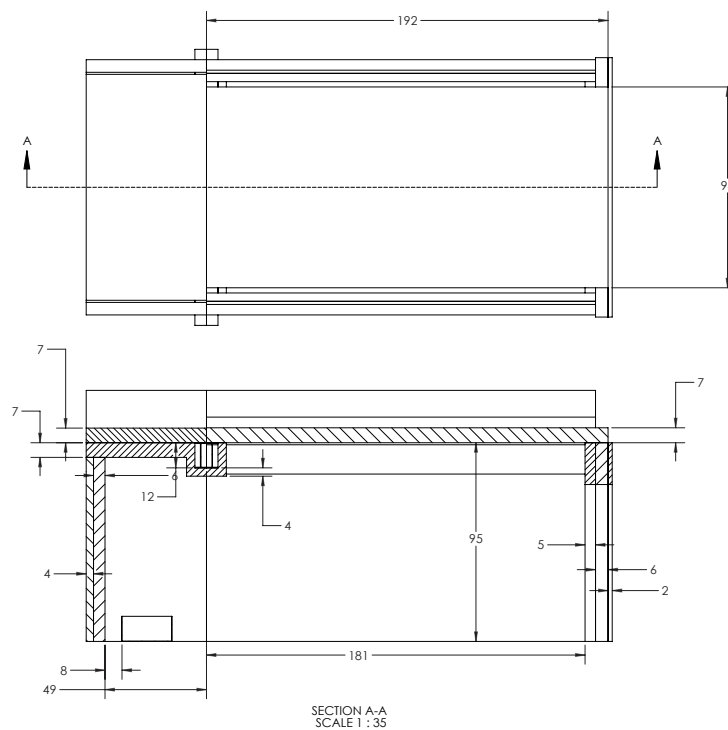

FIGURE X2-3

PLAN VIEW (SECTION) AND SIDE ELEVATION (SECTION) OF TEST ROOM (Units in inches)

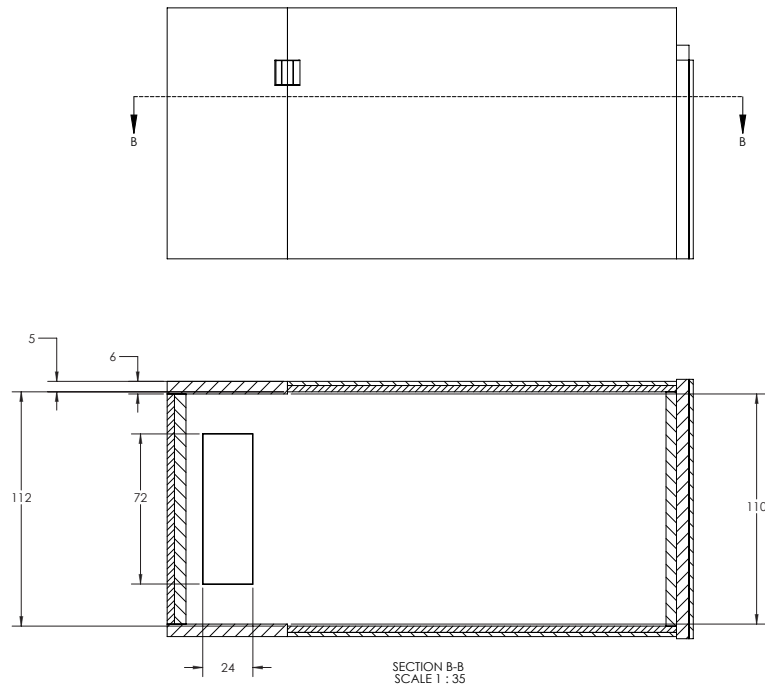

FIGURE X2-4  
**FRONT ELEVATION AND CONSTRUCTION DETAIL TO NARROW GAP ALONG SIDES OF CLT SAMPLE (Units in inches)**

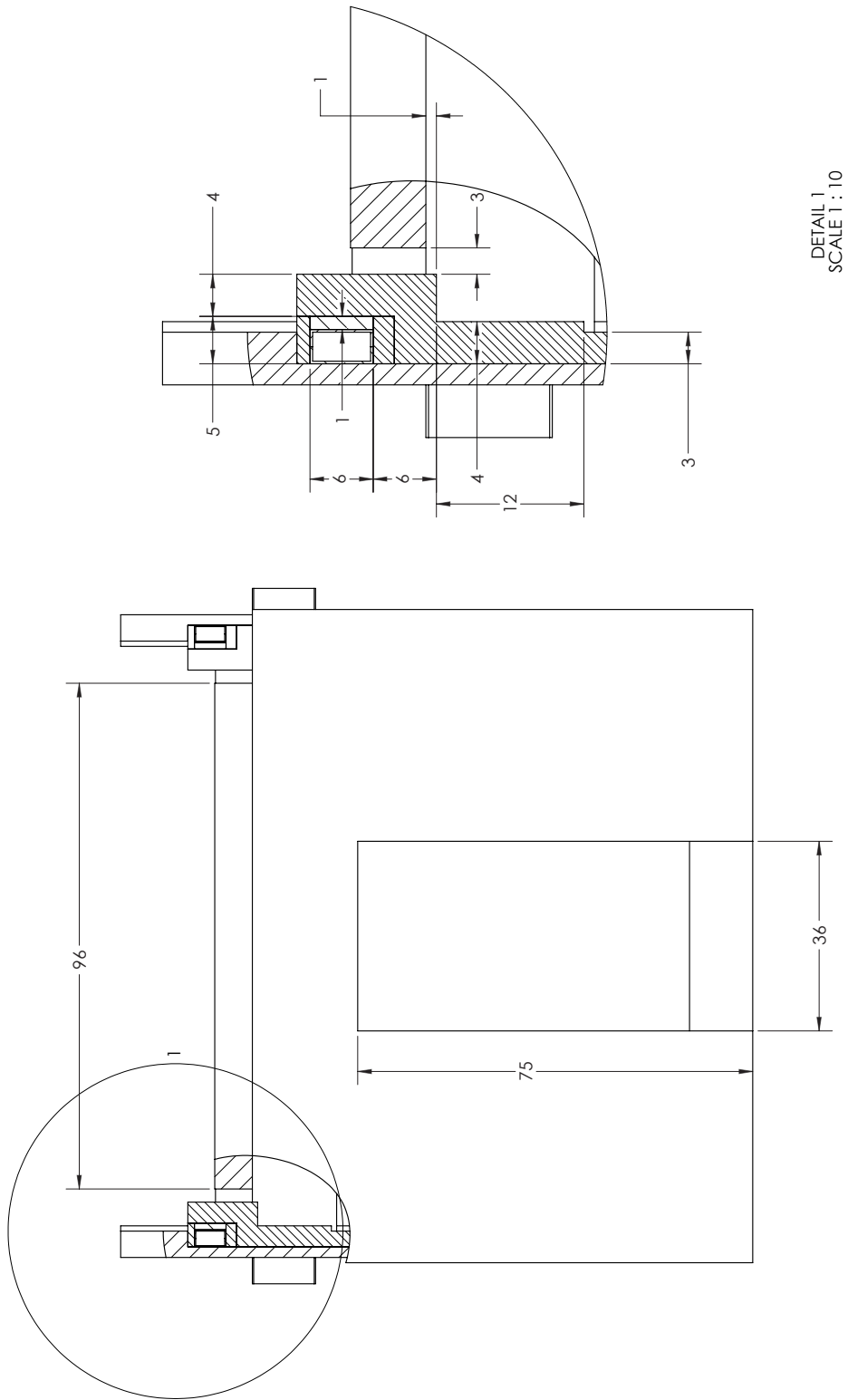



FIGURE X2-5

**PROPANE DIFFUSION BURNER**



FIGURE X2-6

**PICTURE ILLUSTRATING CERAMIC FIBER COVER AROUND PANEL PERIMETER**



FIGURE X2-7

**SCHEMATIC OF BURNER ILLUSTRATING DISTRIBUTION OF PROPANE FLOW**

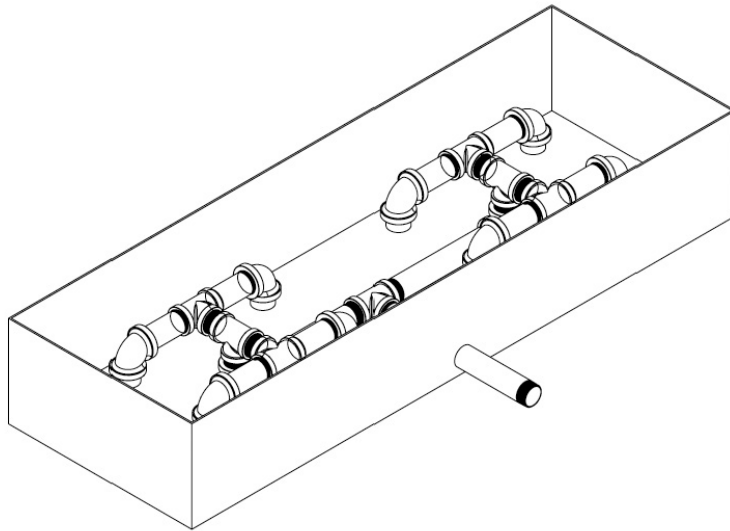
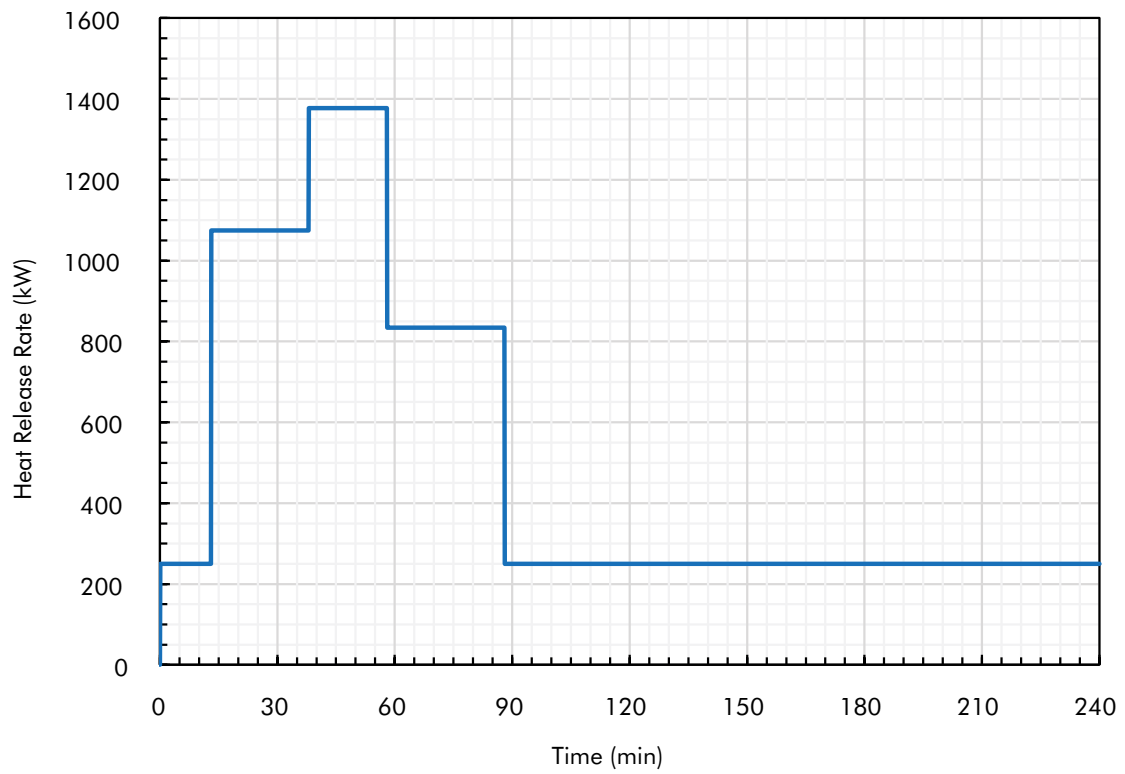

FIGURE X2-8

**BURNER HEAT RELEASE RATE PROFILE**



## APPENDIX X3. Engineering Model Used in the Development of Design Values in Annex A (Non-Mandatory)

### X3.1 General

This appendix provides engineering formulas for the determination of CLT design values published in Annex A based on the shear-analogy model and CSA O86. This methodology has been recognized by the consensus-based canvas committee that developed this standard.

These formulas are applicable to CLT grades and layups that are symmetric using laminations with design properties recognized by the *approved agency*. For other grades and layups, such as unsymmetrical layups or the layups having adjacent layers oriented in the same direction, additional consideration may be necessary when using these formulas.

For calculating the CLT design properties, such as those shown in Tables A2 and A4, the transverse E of the lamination is customarily assumed to be E/30, the longitudinal G of the lamination is assumed to be E/16, and the transverse G of the lamination is assumed to be longitudinal G/10.

### X3.2 Flatwise Bending Moment

$$(F_b S)_{eff,f,0} = \left(\frac{1}{12}\right) 0.85 F_{b,major} S_{eff,f,0} \quad [X3-1 \text{ ASD}]$$

$$(f_b S)_{eff,f,0} = 0.85 f_{b,major} S_{eff,f,0} \quad [X3-1 \text{ LSD}]$$

$$(F_b S)_{eff,f,90} = \left(\frac{1}{12}\right) F_{b,minor} S_{eff,f,90} \quad [X3-2 \text{ ASD}]$$

$$(f_b S)_{eff,f,90} = f_{b,minor} S_{eff,f,90} \quad [X3-2 \text{ LSD}]$$

where

$(F_b S)_{eff,f,0}$  = Effective ASD reference flatwise bending moment of CLT, in lbf-ft/ft of width, in the CLT major strength direction

$(f_b S)_{eff,f,0}$  = Effective LSD flatwise bending moment resistance of CLT, in N-mm/m of width, in the CLT major strength direction

$(F_b S)_{eff,f,90}$  = Effective ASD reference flatwise bending moment of CLT, in lbf-ft/ft of width, in the CLT minor strength direction

$(f_b S)_{eff,f,90}$  = Effective LSD flatwise bending moment resistance of CLT, in N-mm/m of width, in the CLT major strength direction

$F_{b,major}$  = ASD reference bending stress of the lamination in the CLT major strength direction, in psi

- $f_{b,major}$  = LSD specified bending strength of the lamination in the CLT major strength direction, in MPa
- $F_{b,minor}$  = ASD reference bending stress of the lamination in the CLT minor strength direction, in psi
- $f_{b,minor}$  = LSD specified bending strength of the lamination in the CLT minor strength direction, in MPa
- $S_{eff,f,0}$  =  $\frac{(EI)_{eff,f,0}}{E_{major}} \frac{2}{t_p}$ , in in.<sup>3</sup>/ft or mm<sup>3</sup>/m of width, in the CLT major strength direction
- $S_{eff,f,90}$  =  $\frac{(EI)_{eff,f,90}}{E_{minor}} \frac{2}{(t_p - t_1 - t_n)}$ , in in.<sup>3</sup>/ft or mm<sup>3</sup>/m of width, in the CLT minor strength direction
- $(EI)_{eff,f,0}$  = effective flatwise bending stiffness of the CLT, in lbf-in.<sup>2</sup>/ft (N-mm<sup>2</sup>/m) of width, in the CLT major strength direction
- $(EI)_{eff,f,90}$  = effective flatwise bending stiffness of the CLT, in lbf-in.<sup>2</sup>/ft (N-mm<sup>2</sup>/ft) of width, in the CLT minor strength direction
- $E_{major}$  = ASD or LSD modulus of elasticity of the lamination, in psi (MPa), in the CLT major strength direction
- $E_{minor}$  = ASD or LSD modulus of elasticity of the lamination, in psi (MPa), in the CLT minor strength direction
- $t_p$  = gross thickness of CLT, in in. (mm)
- $t_1$  = thickness of the bottom layer(s) of the lamination parallel to the CLT major strength direction, in in. (mm)
- $t_n$  = thickness of the top layer(s) of the lamination parallel to the CLT major strength direction, in in. (mm)

### X3.3 Flatwise Bending Stiffness

$$(EI)_{eff,f,0} = \sum_{i=1}^n E_i b_0 \frac{t_i^3}{12} + \sum_{i=1}^n E_i b_0 t_i z_i^2 \quad [X3-3]$$

$$(EI)_{eff,f,90} = \sum_{i=2}^{n-1} E_i b_{90} \frac{t_i^3}{12} + \sum_{i=2}^{n-1} E_i b_{90} t_i z_i^2 \quad [X3-4]$$

where

- $(EI)_{eff,f,0}$  = Effective flatwise bending stiffness of CLT, in lbf-in.<sup>2</sup>/ft (N-mm<sup>2</sup>/m) of width, in the CLT major strength direction

- $(EI)_{\text{eff},f,90}$  = Effective flatwise bending stiffness of CLT, in lbf-in.<sup>2</sup>/ft (N-mm<sup>2</sup>/m) of width, in the CLT minor strength direction
- $b_0$  = CLT width in the CLT major strength direction, in in./ft (mm/m) of width
- $b_{90}$  = CLT width in the CLT minor strength direction, in in./ft (mm/m) of width
- $E_i$  = modulus of elasticity of the lamination in the  $i$ -th layer, in psi (MPa)
- $G_i$  = modulus of rigidity (shear modulus) of the lamination in the  $i$ -th layer, in psi (MPa)
- $t_i$  = thickness of laminations in the  $i$ -th layer, in in. (mm)
- $z_i$  = distance between the center point of the  $i$ -th layer and the neutral axis, in in. (mm)
- $n$  = number of layers in the CLT

### X3.4 Flatwise Shear Rigidity

$$(GA)_{\text{eff},f,0} = \frac{(t_p - \frac{t_1}{2} - \frac{t_n}{2})^2}{\left[ \left( \frac{t_1}{2G_1 b_0} \right) + \left( \sum_{i=2}^{n-1} \frac{t_i}{G_i b_0} \right) + \left( \frac{t_n}{2G_n b_0} \right) \right]} \quad [\text{X3-5}]$$

$$(GA)_{\text{eff},f,90} = \frac{(t_p - \frac{t_1}{2} - \frac{t_n}{2})^2}{\left[ \left( \frac{t_1}{2G_1 b_{90}} \right) + \left( \sum_{i=2}^{n-1} \frac{t_i}{G_i b_{90}} \right) + \left( \frac{t_n}{2G_n b_{90}} \right) \right]} \quad [\text{X3-6}]$$

where

- $(GA)_{\text{eff},f,0}$  = Effective flatwise shear rigidity of CLT, in lbf/ft (N/m) of width, in the CLT major strength direction
- $(GA)_{\text{eff},f,90}$  = Effective flatwise shear rigidity of CLT, in lbf/ft (N/m) of width, in the CLT minor strength direction

Other terms are as defined in previously sections.

**X3.5 Flatwise (Rolling) Shear Capacity**

$$V_{s,0} = F_{s,minor} \frac{2 A_{gross,0}}{3} \quad [X3-7 \text{ ASD}]$$

$$v_{s,0} = f_{s,minor} \frac{2 A_{gross,0}}{3} \quad [X3-7 \text{ LSD}]$$

$$V_{s,90} = F_{s,major} \frac{2 A_{gross,90}}{3} \quad [X3-8 \text{ ASD}]$$

$$v_{s,90} = f_{s,major} \frac{2 A_{gross,90}}{3} \quad [X3-8 \text{ LSD}]$$

where

$V_{s,0}$  = ASD reference flatwise shear capacity, in lbf/ft of width, in the CLT major strength direction

$v_{s,0}$  = LSD flatwise shear resistance, in N/m of width, in the CLT major strength direction

$V_{s,90}$  = ASD reference flatwise shear capacity, in lbf/ft of width, in the CLT minor strength direction

$v_{s,90}$  = LSD flatwise shear resistance, in N/m of width, in the CLT minor strength direction

$F_{s,major}$  = ASD reference planar (rolling) shear stress of a lamination in the CLT major strength direction =  $\frac{F_{v,major}}{3}$ , in psi

$F_{v,major}$  = ASD reference shear stress of a lamination in the CLT major strength direction, in psi

$f_{s,major}$  = LSD specified planar (rolling) shear strength of a lamination in the CLT major strength direction =  $\frac{f_{v,major}}{3}$ , in MPa

$f_{v,major}$  = LSD specified shear strength of a lamination in the CLT major strength direction, in MPa

$F_{s,minor}$  = ASD reference planar (rolling) shear stress of a lamination in the CLT minor strength direction =  $\frac{F_{v,minor}}{3}$ , in psi

$F_{v,minor}$  = ASD reference shear stress of a lamination in the CLT minor strength direction, in psi

$f_{s,minor}$  = LSD specified planar (rolling) shear strength of a lamination in the CLT minor strength direction =  $\frac{f_{v,minor}}{3}$ , in MPa

$f_{v,minor}$  = LSD specified shear strength of a lamination in the CLT minor strength direction, in MPa

$A_{gross,0}$  = gross cross-sectional area of CLT, in in.<sup>2</sup>/ft (mm<sup>2</sup>/m) of width

$A_{gross,90}$  = gross cross-sectional area of CLT excluding the outermost longitudinal layers, in in.<sup>2</sup>/ft (mm<sup>2</sup>/m) of width

NOTE X3-1: For a CLT panel manufactured with multiple longitudinal outermost layers, all these are excluded from  $A_{gross,90}$ .

## APPENDIX X4. History of Standard (Non-Mandatory)

In March 2010, the APA Standards Committee on Standard for Performance-Rated Cross-Laminated Timber was formed to develop a national standard under the consensus processes accredited by the American National Standards Institute (ANSI). This national consensus standard, designated as ANSI/APA PRG 320, was developed based on broad input from around the world. It should be especially recognized that this standard incorporates draft standards that were developed by FPInnovations in Canada, as part of the joint effort between the U.S. and Canada in the development of a bi-national CLT standard.

The first version of this standard was approved by ANSI for publication on December 20, 2011. Subsequent revisions resulted in the publication of the following versions:

- ANSI/APA PRG 320-2012 on October 30, 2012,
- ANSI/APA PRG 320-2017 on October 6, 2017,
- ANSI/APA PRG 320-2018 on February 6, 2018, and
- ANSI/APA PRG 320-2019 (this standard).

Inquiries or suggestions for improvement of this standard should be directed to:

Secretariat, ANSI/APA PRG 320  
 APA – The Engineered Wood Association  
 7011 South 19th Street  
 Tacoma, WA 98466  
 Internet address: [www.apawood.org](http://www.apawood.org)  
 e-mail address: [help@apawood.org](mailto:help@apawood.org)

The names of the ANSI/APA PRG 320 Committee members when this version of the standard is published are as shown below. The current list of the committee membership is available from the committee secretariat upon request.

<b>Name</b>	<b>Affiliation</b>	<b>Note</b>
Deepareddy Akula	Stella-Jones (Formerly McFarland Cascade)	
Joshua Bartlett	Franklin International	
Mark Bartel	International Beams	
Kevin Below	Cross Laminated Timber Canada Inc.	
Todd Black	DR Johnson Wood Innovations	
Hans-Erik Blomgren	Katerra	
Scott Breneman	WoodWorks - Wood Products Council	ExSub Member
Darryl Byle	CLT Solutions LLC	
Kevin Cheung	Western Wood Products Association	
Mark Clark	Momentive Inc.	
Steve Craft	CHM Fire Consultants Ltd.	
Randy Daudet	Simpson Strong-Tie	
Don DeVisser	Pacific Lumber Inspection Bureau	
Bruno Di Lenardo	Canadian Construction Materials Centre	
Brad Douglas	American Wood Council	
Pat Farrell	Freres Lumber Company	
Julie Frappier	Nordic Structures	Vice-Chair
Sylvain Gagnon	FPIinnovations	
Bill Gareis	Ashland Inc.	
Bill Gould	ICC Evaluation Service Inc.	
Jim Henjum	SmartLam LLC	
Ben Herzog	University of Maine	
Frank Lam	University of British Columbia	
Dean Lewis	DCI Engineers	
Jeff Linville	Weyerhaeuser Company	
Robert Malczyk	Equilibrium Consulting Inc.	
Andre Morf	Structurlam Products, LP	
Jeff Morrison	Rosboro LLC	
David Moses	Moses Structural Engineers Inc.	
Lech Muszynski	Oregon State University	
John Neels	National Lumber Grades Authority	
Scott Nyseth	Stonewood Structural Engineers Inc.	
Ciprian Pirvu	WoodTech Consulting	
Henry Quesada-Pineda	Virginia Tech University	
Douglas Rammer	USDA Forest Products Laboratory	
Alexander Salenikovich	Université Laval	ExSub Member
Sheldon Shi	University of North Texas	
Scott Skinner	Akzo Nobel Coatings Inc.	
Kurt Stochlia	KSPE Inc.	
Phil Vacca	Louisiana-Pacific Corp.	
Chris Whelan	Henkel Corporation	
Tom Williamson	T.Williamson-Timber Engineering LLC	Chair
Steve Winistorfer	PFS TECO	
B.J. Yeh	APA – The Engineered Wood Association	Secretariat
Cory Zurell	Blackwell Structural Engineers	



# ANSI/APA PRG 320-2019 Standard for Performance-Rated Cross-Laminated Timber

## **APA HEADQUARTERS**

7011 So. 19th St. ▪ Tacoma, Washington 98466 ▪ (253) 565-6600 ▪ Fax: (253) 565-7265

## **PRODUCT SUPPORT HELP DESK**

(253) 620-7400 ▪ [help@apawood.org](mailto:help@apawood.org)

Form No. PRG 320-2019/Issued January 2020

